

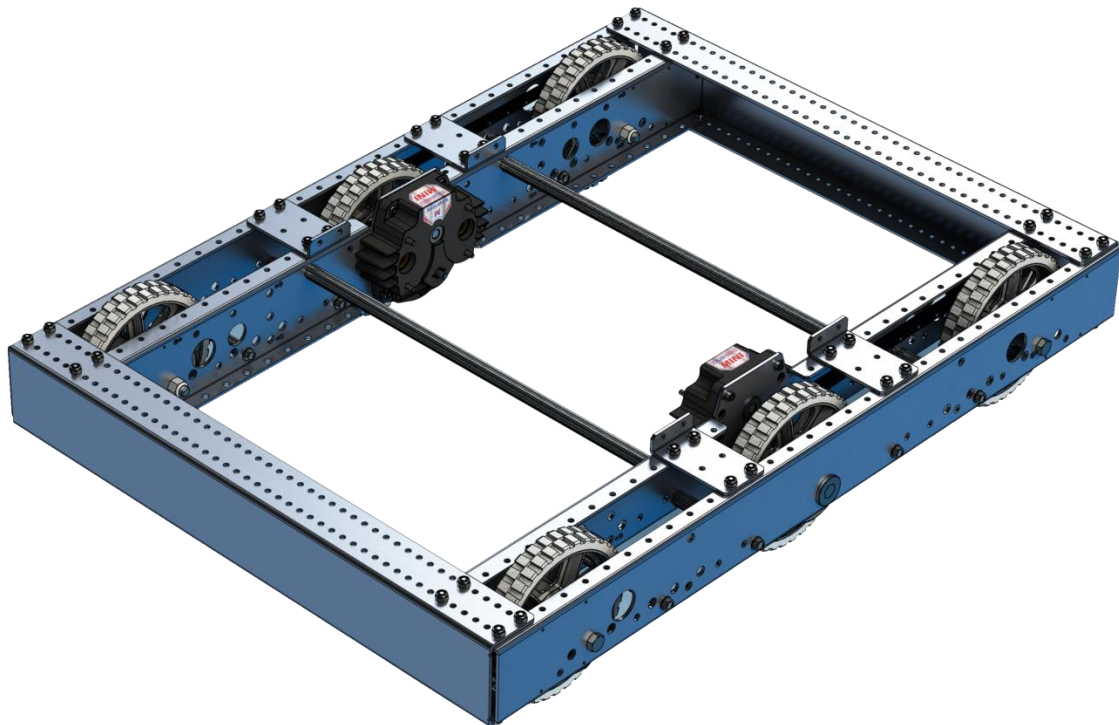

User Guide

*AM14U3 Chassis Base Kit for the
2016 FIRST® Robotics Competition*



AndyMark – Your Robot Parts Experts

AndyMark wishes the best of luck to all *FIRST* Teams in the 2016 *FIRST*® Robotics Competition season!

AndyMark, Inc. was founded in 2004 by Andy Baker and Mark Koors to design and sell unique mechanical parts for competition and educational robotics. Through their volunteer work with *FIRST*® Robotics Competition events they identified a niche market and began designing and selling robotics components for *FIRST* teams. At that time, many designs were being shared and re-created, but finding the correct fabrication resources for these parts was difficult for some *FRC* teams. AndyMark has been a proud supplier to the *FIRST*® Robotics Competition since 2005.

System Overview









The 2016 AM14U3 Drive Chassis Base Kit is designed to help teams accomplish the basics in the 2016 *FIRST* Robotics Competition. The AM14U3 Base Kit includes standard AndyMark products and is designed to also work with additional AndyMark products.

Additional Instructions Available

We encourage customers to seek product information at **AndyMark.com**, contact us via e-mail at **support@andymark.com**, or call Toll-Free **877-868-4770** with questions about any of our products.

Detailed assembly tips and instructional videos can be found at AndyMark.com/FRCVideos. Additional resources, drawings, and CAD are available on the AndyMark.com/KOP web page.

AM14U3 Recommended Hand Tool List (not included)

Component	Part Number	QTY	Part Photo
Hammer	Available at your local hardware store.	1	
Cordless Drill or Driver	Available at your local hardware store.	1	
3/8" Magnetic Nut Setter	am-2755	1	
5/16" Magnetic Nut Setter	am-2754	1	
9/16" Socket, 3/8" Drive	am-2743	1	
3/8" Socket, 3/8" Drive	am-2740	1	
5/32" Ball End Hex Driver	am-2751	1	
3/8" Drive Quick Release Ratchet	am-2753	1	
1/2" - 9/16" Open-End Wrench	am-2746	1	

Wheel Assembly Bill of Materials

Component	Part Number	Quantity	Part Photo
6" HiGrip Wheel	am-0940a	6	
500EX Hex Hub	am-2568	2	
Pulley Half, 42 Tooth	am-2234-half	16	
Gates HTD 15mm wide, 160 Tooth Belt for Long Chassis	am-2266	4	
Gates HTD 15mm wide, 120 Tooth Belt for Wide Chassis	am-2704	4	
Gates HTD 15mm wide, 131 Tooth Belt for Square Chassis	am-2571	4	
Screw Kit – (am-14U3_white)			
10-24 x 1.25" Thread Forming Screws	am-1266	48	
Bearing Kit – (am-14U3_LightGreen)			
1614ZZ Bearing	am-0209	8	
FR8ZZ - HexHD Bearing	am-2986	2	

Toughbox Mini Overview

Each AM14U3 Chassis Base Kit includes two (2) **AndyMark** Toughbox Mini Gearboxes, unassembled ([am-2598 107](#)). Each Toughbox Mini includes the parts needed to mount two 2.5" CIM motors ([am-0255](#)). Each gearbox has mounting holes for optional encoders such as the USDigital E4T Optical Encoder ([am-3132](#)).

Gearbox Specifications:

- Gear Profile: 20 DP, 14.5° pressure angle
- Gear Material: Cold-formed 4140 Steel
- Gear Ratio: 10.71:1
 - CIM Gear: 14 Tooth (8mm bore w/ 2mm keyway)
 - Large Cluster Gear: 50 Tooth (3/8" Hex bore)
 - Small Cluster Gear: 16 Tooth (3/8" Hex bore)*
 - Large Output Gear: 48 Tooth (1/2" Hex bore)*
- Output Shaft: 1/2" Hex, 4140 Steel
- Housing Material: Nylon 6/6 with long fiber reinforcements

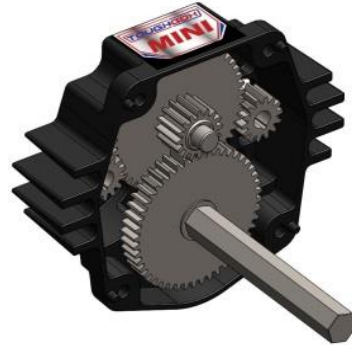



*To change the drive speed of the AM14U3, different gear ratios can be used in the Toughbox Mini. The AM14U3 features a center wheel directly driven by a TB Mini Hex Output Shaft. To change the ratio and drive speed, the standard 16 tooth Small Cluster Gear and 48 tooth Large Output Gear will need to be replaced with two gears totaling 64 teeth.

More information about these optional gears can be found at "[AndyMark.com/TBmini](#)".

Ratio	CIM Gear	Lg. Cluster	Sm. Cluster	Lg. Output	AM14U3 Speed**
5.95:1	14T (am-0034)	50T (am-0149)	24T (am-0177)	40T (am-0178)	18.0 ft/sec
7.31:1	14T (am-0034)	50T (am-0149)	21T (am-2564)	43T (am-2565)	14.7 ft/sec
8.45:1	14T (am-0034)	50T (am-0149)	19T (am-0176)	45T (am-0179)	12.7 ft/sec
10.71:1 (included)	14T (am-0034)	50T (am-0149)	16T (am-0747)	48T (am-0885)	10.0 ft/sec
12.75:1	14T (am-0034)	50T (am-0149)	14T (am-0151)	50T (am-0150)	8.4 ft/sec

**AM14U3 speed estimation is based on calculations using 6" wheels, and one CIM motor per TB Mini running at 4100 rpm, or 75% of free speed.

Toughbox Mini Bill of Materials

Component	Part Number	Quantity	Part Photo
TB Mini Housing	am-0650	1	
TB Mini Hex Output Shaft	am-2566	1	
TB Mini Small Hex Shaft	am-0152	1	

TB Mini Kit 1 – Gears – (am-14U3_Yellow)			
50 Tooth, 3/8" Hex Gear	am-0149	1	
14 Tooth, 8mm CIM Gear	am-0034	2	
16 Tooth, 3/8" Hex Gear	am-0747	1	
48 Tooth, 1/2" Hex Gear	am-0885	1	
TB Mini Kit 2 – Bearings – (am-14U3_Purple)			
R6ZZ Bearing	am-0516	2	
FR6ZZ Bearing	am-0028	1	
FR8ZZ HexHD Bearing	am-2986	1	
TB Mini Kit 3 – CIM Hardware – (am-14U3_Red)			
2x2x10mm Machine Key	am-1121	2	
5/16" Washer	am-1009	4	
8mm Retaining Clip	am-0033	2	
10-32 x 0.625" SHCS with Nylon Thread Lock Patch	am-1120	4	
TB Mini Kit 4 – TB Hardware – (am-14U3_DarkBlue)			
10-32 x 0.75" SHCS	am-1047	4	
10-32 Nylock Nut	am-1042	4	
Red Tacky Grease Pack	am-2768	1	
1/2" E-Clip Ring	am-0206	1	

AM14U3 Chassis Frame Bill of Materials

Component	Part Number	QTY	Part Photo
AM14U3 Outer Plate	am-2951a	2	
AM14U3 Inner Plate	am-2952a	2	
AM14U3 End Plate	am-2953a	2	
2x3 Hole Bracket	am-2954	4	
500 Churro, 24.25"	am-2974	2	
500 Churro, 3.375"	am-2569	8	
Chassis Kit 1 – Support Screws – (am-14U3_LightBlue)			
1/4-20 x 0.75" Thread Rolling Screw	am-1310	20	
Chassis Kit 2 – Axle Bolts – (am-14U3_Orange)			
3/8-16 x 4.25" HHS Bolt	am-1297	4	
3/8-16 Nylock Nut	am-1054	4	
Chassis Kit 3 – Wheel Spacers – (am-14U3_Green)			
0.570" Hex Spacer	am-1305	2	
Plastic Spacer 0.280"	am-1306	4	
Plastic Spacer 0.850"	am-1307	4	
Chassis Kit 4 – 10-32 Hardware – (am-14U3_Gray)			
10-32 x 0.5" SHCS	am-1002	40	
10-32 Nylock Nut	am-1042	40	

Frame Diagrams & Cut Lines:

The AM14U3 is designed for multiple configurations. Chassis pieces **should be measured** and cut down to size; some possible configurations are shown below. Ensure that your final frame size complies with all 2016 FRC® rules. Belts for **LONG**, **SQUARE** and **WIDE** configurations are included.

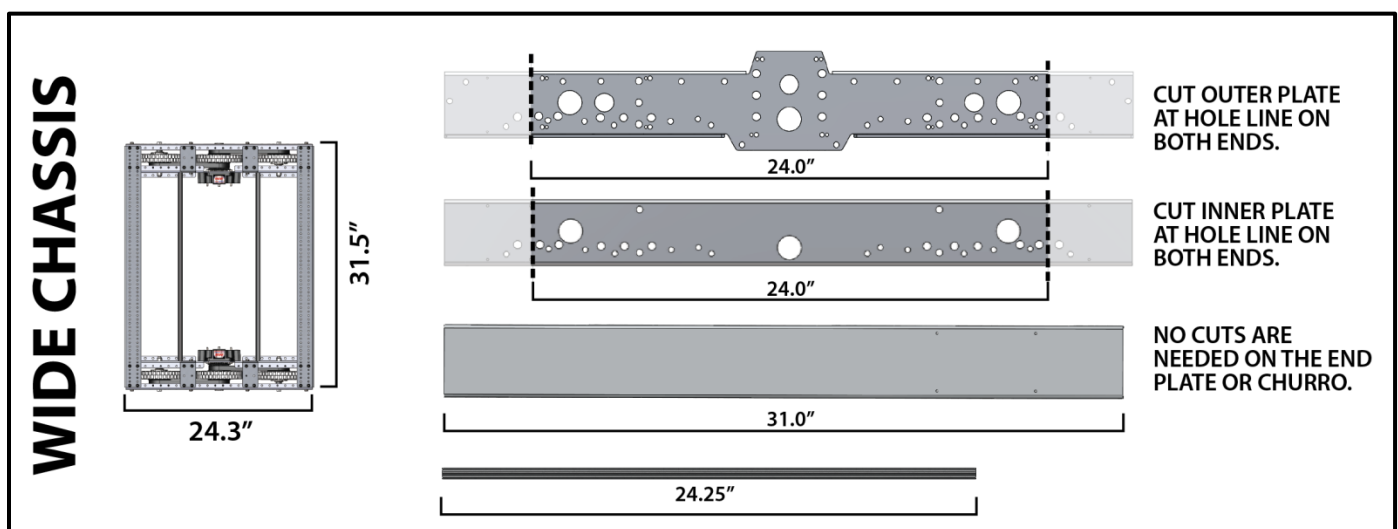
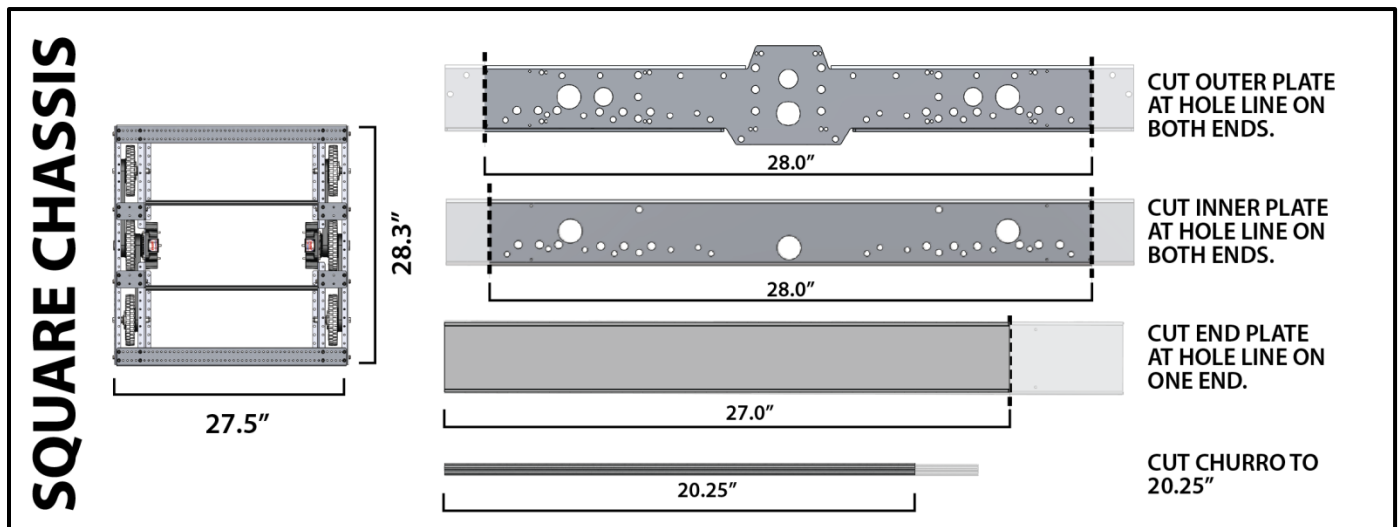
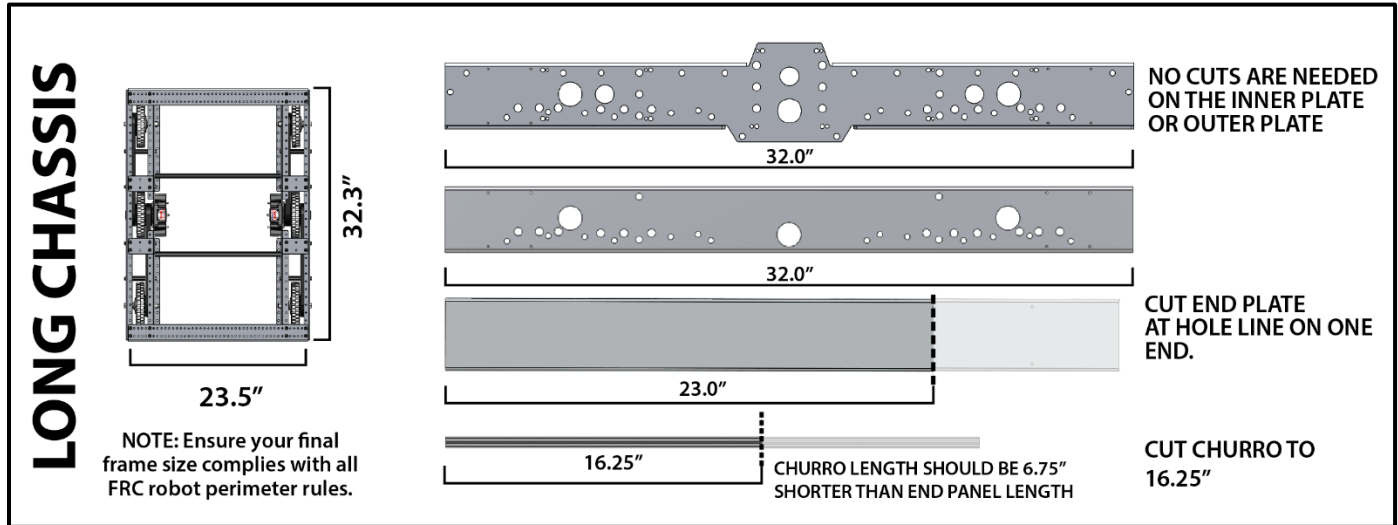

6" HiGrip Wheel and Pulley Assembly Instructions

Outer Wheels (QTY 4)

Step 1: Add two pulley halves (am-2234-half) to the wheel (am-0940a).



Step 2: Using six 10-24 x 1.25" (am-1266) thread forming screws, attach the pulley halves to the wheel.

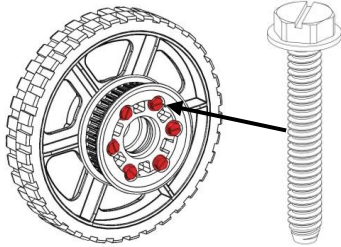

Step 3: Press two 1614ZZ Bearings (am-0209) into each side of the wheel/pulley.

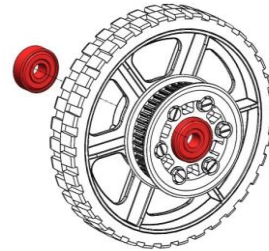

4X

NOTE: Tighten the screws in a triangle pattern to ensure the pulley aligns evenly on the wheel.

Center Wheels (QTY 2)

Step 1: Add two pulley halves (am-2234-half) to the wheel (am-0940a).



Step 2: Using six 10-24 x 1.25" (am-1266) thread forming screws attach the pulley halves to the wheel.

NOTE: Tighten the screws in a triangle pattern to ensure the pulley aligns evenly on the wheel.

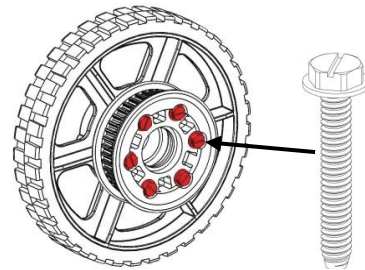

Step 3: Flip wheel over.

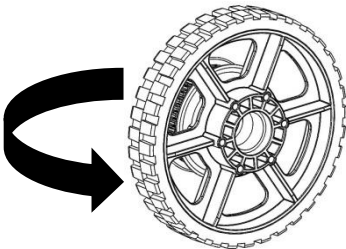

Step 4: Add two more pulley halves (am-2234-half) to the wheel.



Step 5: Insert one 500EX Hex Hub (am-2568) into the pulley on one side of the wheel.



Step 6: Add six 10-24 x 1.25" (am-1266) thread forming screws to attach the pulley and hub to the wheel.

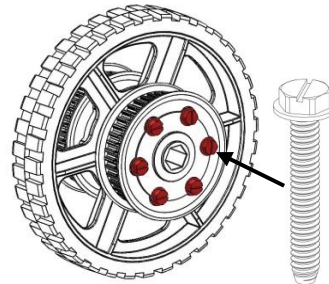

2X

Toughbox Mini & Chassis Assembly Instructions

Step 1: Press two R6ZZ bearings (am-0516) into the two center holes of the TB Mini Housing (am-0650).

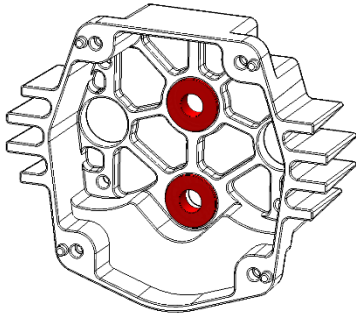

Step 2: Insert the TB Small Hex Shaft (am-0152) into the R6ZZ bearing closest to the flat edge of the housing.

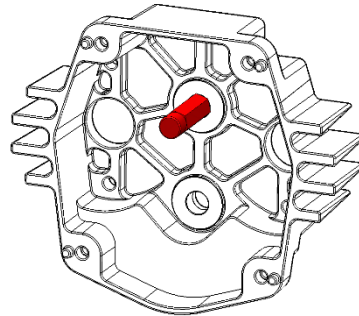

Step 3: Place the 50 tooth gear (am-0149) on the TB Small Hex Shaft with **flat side up**.

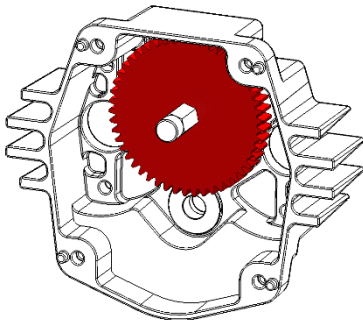

Step 4: Place the 16 tooth gear (am-0747) on the TB Small Hex Shaft with **flat side down**.

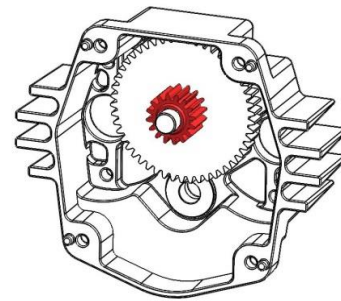

Step 5: Tap the 1/2" E-Clip (am-0206) onto the groove on the TB Hex Output Shaft (am-2566).

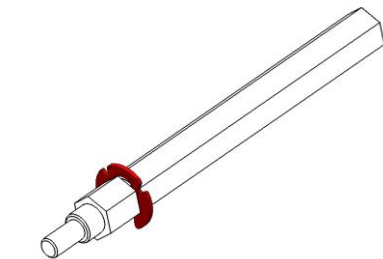

Step 6: Insert the small end of the TB Hex Output Shaft (am-2566) into the other R6ZZ bearing.

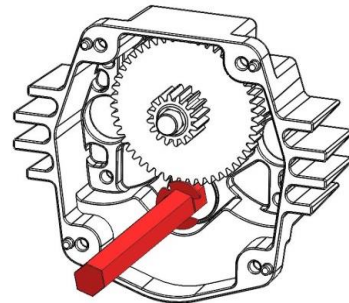

Step 7: Place the 48 Tooth Gear (am-0885) on TB Hex Output Shaft **flat side down**.

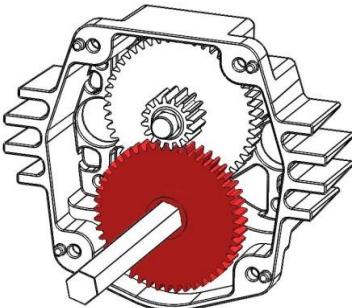

Step 8: Apply Red Tacky Grease (am-2768) to all of the gear teeth.

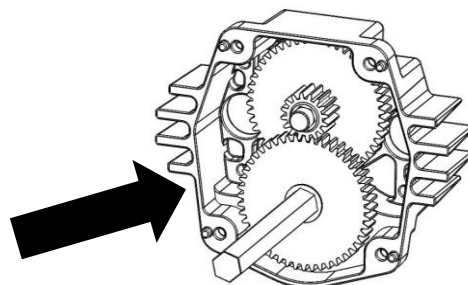

Step 9: Press the FR6ZZ (am-0028) and FR8ZZ-HexHD (am-2986) bearings into center holes on the Inner Plate (am-2952a) with the **bearing flanges on the same side** as the bottom flange. This will keep the bearings from falling out during operation.

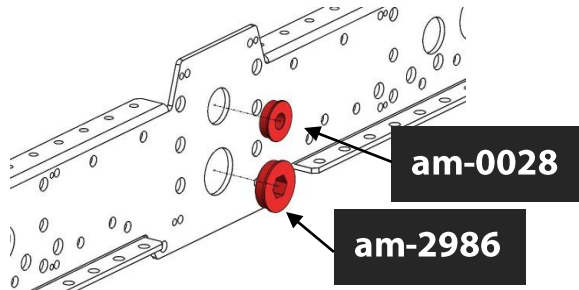

Step 11: Attach the TB Mini to Inner Plate with four 10-32 x 0.75" SHCS (am-1047) and four 10-32 Nylock nuts (am-1042). The nuts will fit into the hex pockets on the TB Mini housing and will hold the nut while tightening.

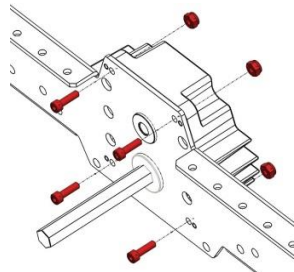

Step 10: Place the TB Mini onto the Inner Plate using the plastic studs to align the housing. The bottom flanged edge of the Inner Plate will be facing towards the gearbox housing.

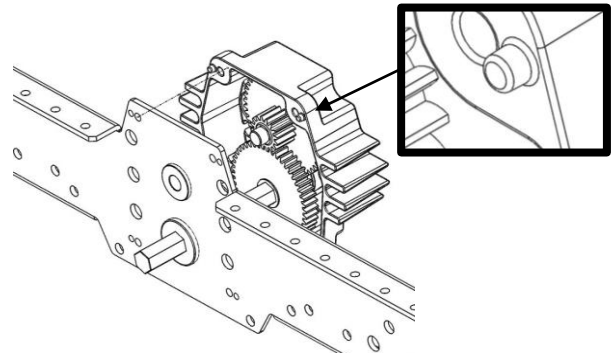

Step 12: Place two 5/16" Washers (am-1009) onto the CIM Motor shaft. Place the 2x2x10mm Machine Key (am-1121) into the keyway of the motor shaft. Push the 14 Tooth, 8mm Key Gear onto the shaft, to the face of the washers, while aligning the keyway with the machine key. Use a 7/16" socket to press the 8mm Retaining Clip (am-0033) onto the face of the gear.

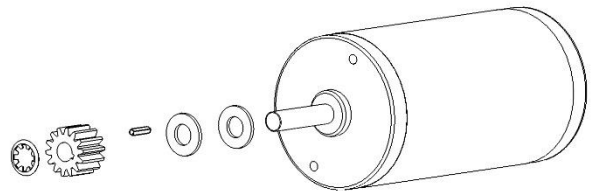

NOTE: The gears should spin freely when the shaft is rotated by hand

Step 13: Line up the CIM motors with the mounting holes in the TB Mini. The housing can be used to align the motor. Secure the CIM motors (am-0255) to the TB Mini Housing with two each 10-32 x 0.625" SHCS w/ Nylon Patch (am-1120).

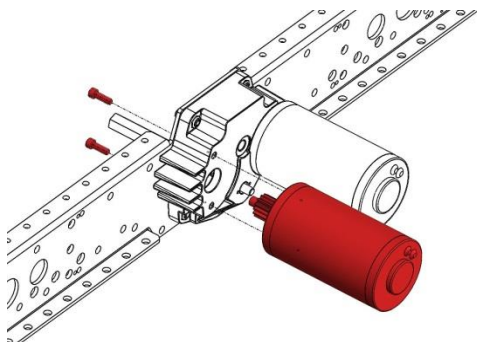

Step 14: Attach **four** 3.375" Churro Standoffs with 1/4-20 x 0.75" Thread Forming Screws (am-1310) onto the Inside Plate. A 1/2" wrench can be used to hold the churro while tightening.

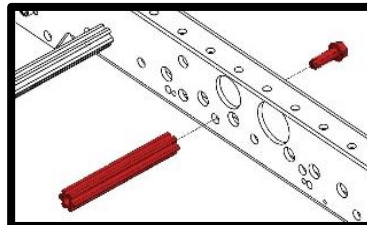

NOTE: The Churro Standoffs are intended to help with the structure of the chassis. Be sure to install four on each Inner Plate.

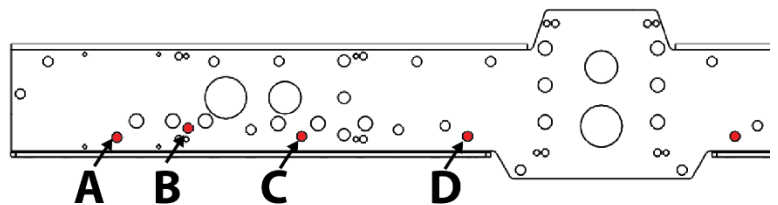

LONG uses holes C & D
SQUARE uses holes A & D
WIDE uses holes B & D

Step 15: Place a Center Wheel Assembly onto the TB Hex Output shaft with the hub facing towards the Inner Plate.

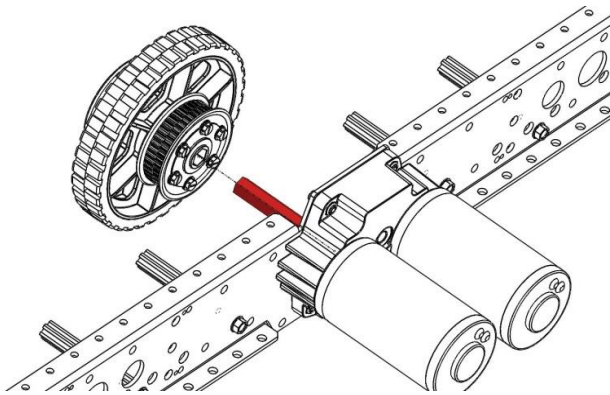

Step 16: Place the Hex Spacer (am-1305) onto the TB Hex Output shaft and press into the pulley. The shaft will help to align the spacer hex bore with the wheel hub hex bore.

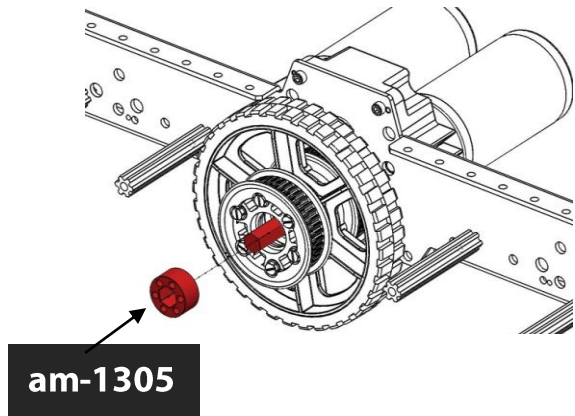

Step 17: Press the FR8ZZ-HexHD Bearing (am-2986) into the center hole of the Outer Plate (am-2951a). The bearing flange will be on the same side as the plate flanges to ensure the bearing does not fall out during operation.

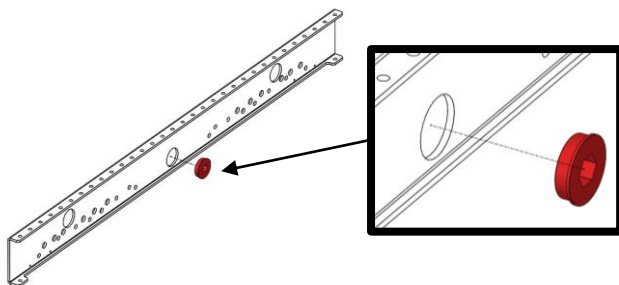

Step 18: There are different axle bolt locations for the different chassis configurations. Slide an axle bolt (am-1297) into the correct axle hole on the Outer Plate.

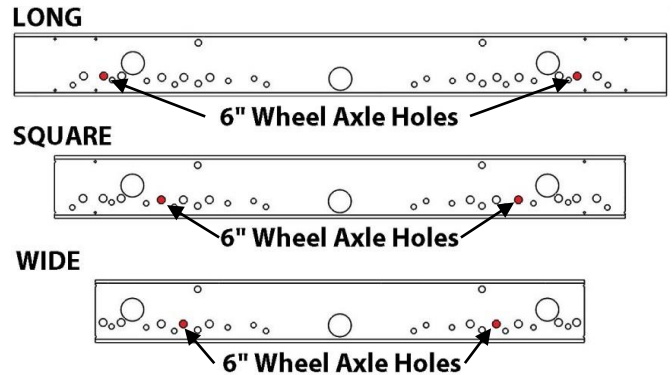

Step 19: Add the long spacer (am-1307), Outer Wheel Assembly and the short spacer (am-1306) onto the axle bolt. The shorter 0.28" (am-1306) spacer is used on the pulley side of the wheel.

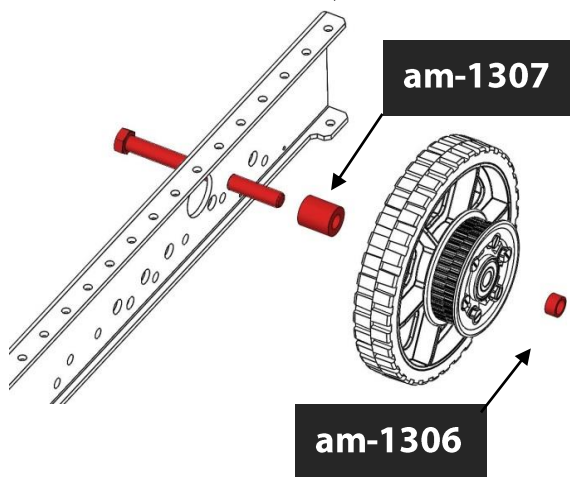

Step 20: For the second Outer Wheel Assembly on this side, the spacer and wheel orientation is reversed to allow one pulley on either side to line up with a Center Wheel Assembly pulley. The front and back wheels will be in opposite orientations.

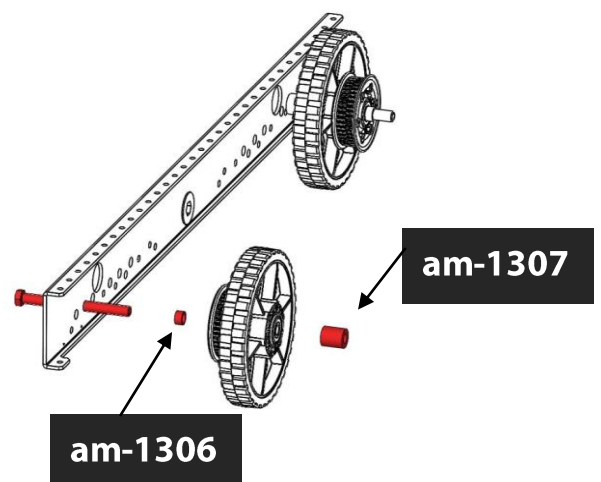

Step 21: Place a belt on each Outer Wheel pulley and wrap them around the Center Wheel pulleys. Carefully line up and place the Outer Plate assembly onto the Inner Plate assembly. The axle bolts will slide through corresponding bolt holes on the Inner Plate and the TB Mini shaft will slide through the FR8ZZ-HexHD bearing on the Outer Plate.

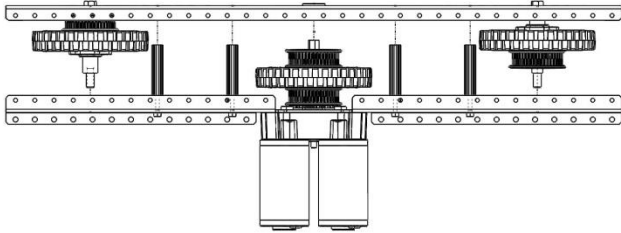

Step 22: Finger tighten the axle bolts with the 3/8-16 Nylock Nuts (am-1054) to secure the assembly. Attach the Outer Plate to the churro standoffs using 1/4"-20 x 0.75" Thread Forming Screws (am-1310).

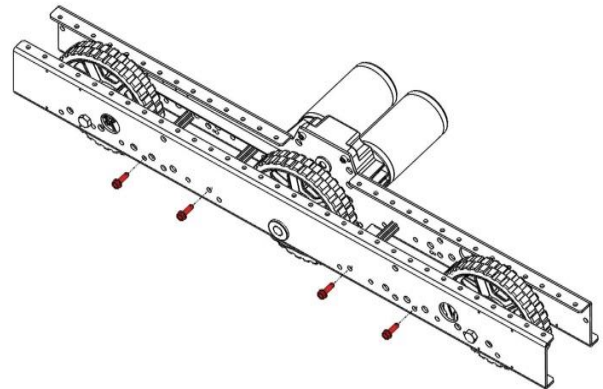

*The long chassis requires 160 tooth belts (am-2266).
The wide chassis requires 120 tooth belts (am-2704).
The square chassis requires 131 tooth belts (am-2571).*

Step 23: Tighten down the axle bolts. The spacers should be flush with the Inner Plate but the wheel should still easily turn.

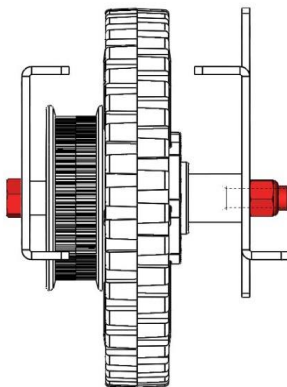

Step 24: You have made one side drive module. Repeat steps 1-23 to create the other drive module.

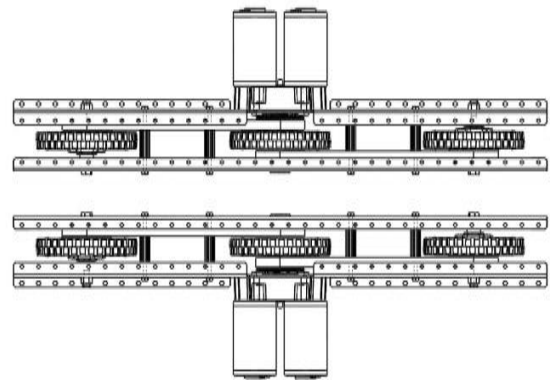

NOTE: The belts should be parallel to the side plates.

Step 25: Attach End Plates to the drive modules using #10-32 x 0.5" SHCS and #10-32 Nylock Nuts. **It is recommended that the nuts be installed on the outside faces of the End Sheet for accessibility.**

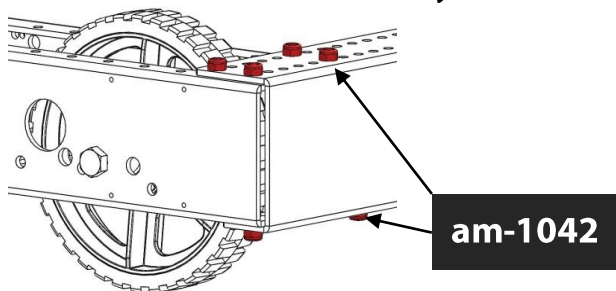

Step 26: Add the Long Churro Tubes (am-2974) and 2x3 Hole Brackets (am-2954) as stiffeners across the robot frame. Feel free to move these to other holes to accommodate electronics and other mechanisms.

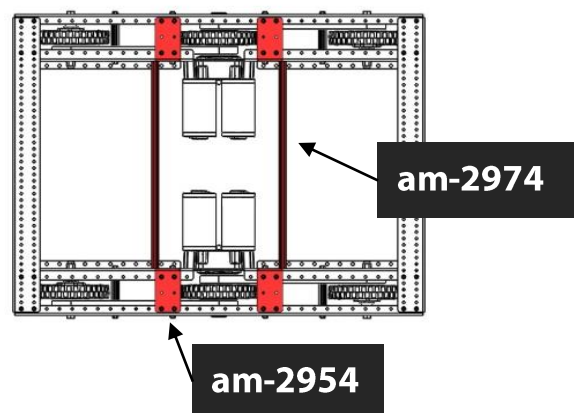

NOTE: The long chassis will use 6 screws and nuts per corner. The wide and square configurations will use 5 screws and nuts per corner.