

4

3

2

1



REVISION HISTORY			
REV.	DESCRIPTION	DATE	DRAWN BY
1	ORIGINAL PRINT	8/9/2018	N. LAWRENCE

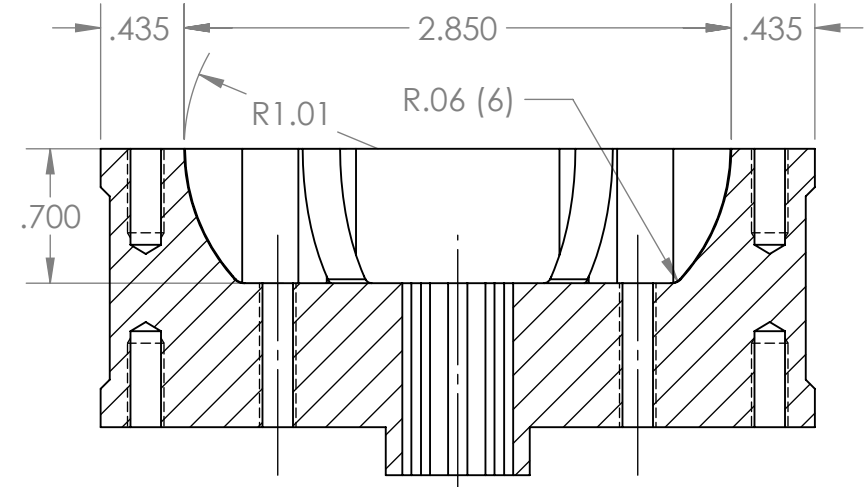
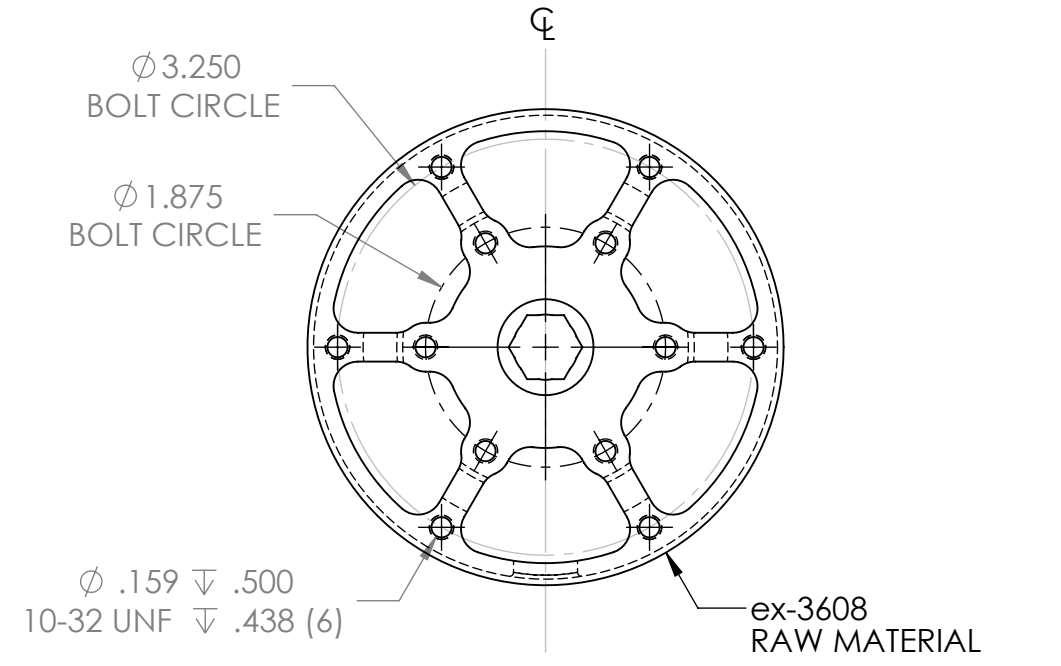
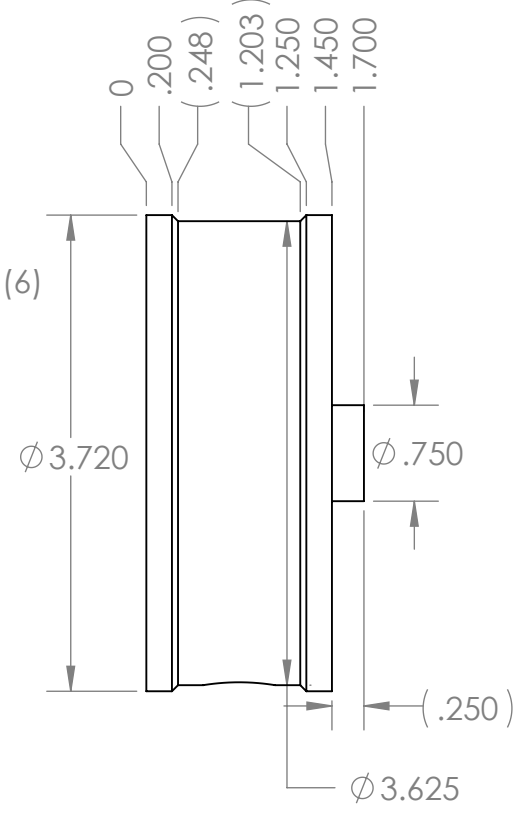
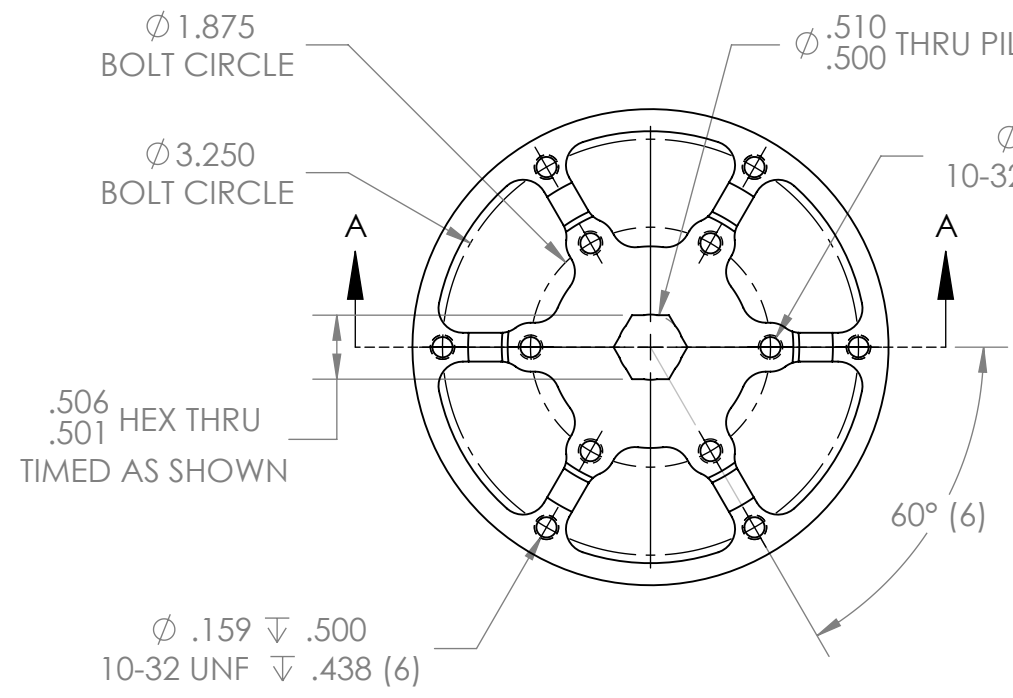

SECTION A-A  
SCALE 1 : 1

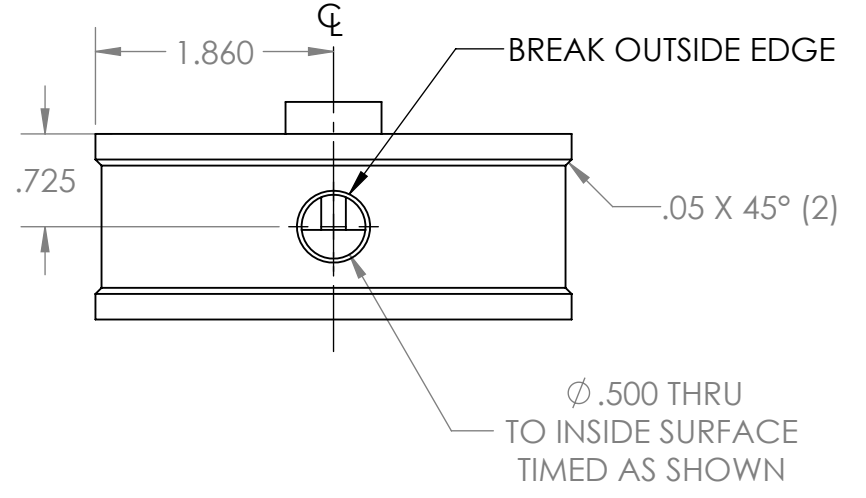

\*\*\* SEE CAD FOR ADDITIONAL TOOLPATH INFO\*\*\*

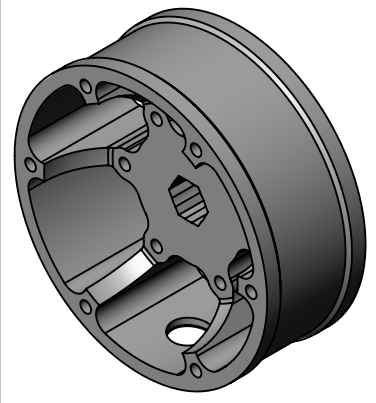

UNLESS OTHERWISE SPECIFIED:		COMMENTS:				
<b>DIMENSIONS ARE IN INCHES</b>		DUAL DIMENSIONS ARE IN MILLIMETERS.				
TOLERANCES:		BREAK ALL SHARP EDGES.		SIZE DWG. NO. REV		
FRACTIONAL	$\pm$ 1/16			B am-3932 1		
ANGULAR: MACH	$\pm$ 1°			SCALE: 1:1.5 SHEET 1 OF 1		
ANGULAR: BEND	$\pm$ 5°					
ONE PLACE DECIMAL	$\pm$ 0.1					
TWO PLACE DECIMAL	$\pm$ 0.01					
THREE PLACE DECIMAL	$\pm$ 0.005					
FOUR PLACE DECIMAL	$\pm$ 0.0005					
MATERIAL	6061-T6 AL	NAME	DATE			
FINISH	TUMBLER	KK	8/16/18			
DO NOT SCALE DRAWING		ENG APPR.				
		MFG APPR.				
		Q.A.				

4

3

2

1

A

A