

4

3

2

1

REVISION HISTORY			
REV.	DESCRIPTION	DATE	DRAWN BY
1	ORIGINAL PRINT	12/6/2018	N. LAWRENCE

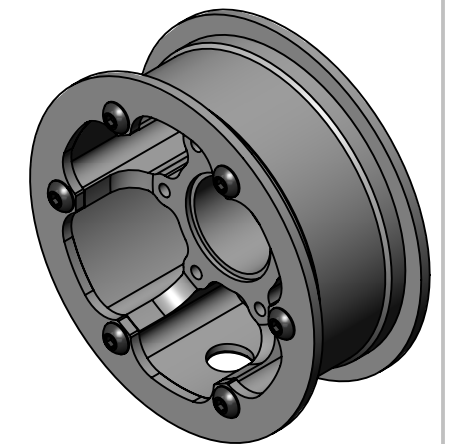
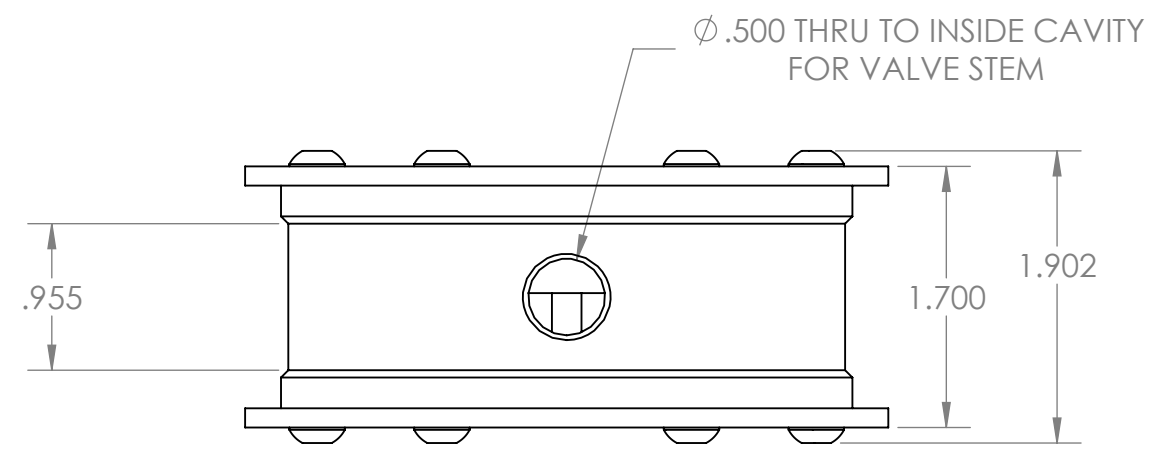
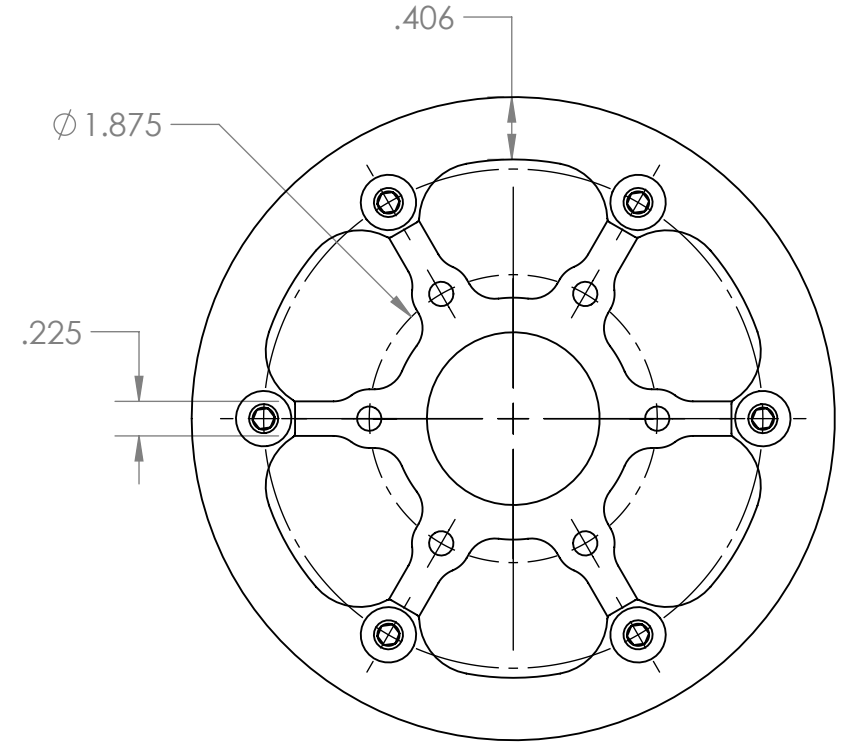
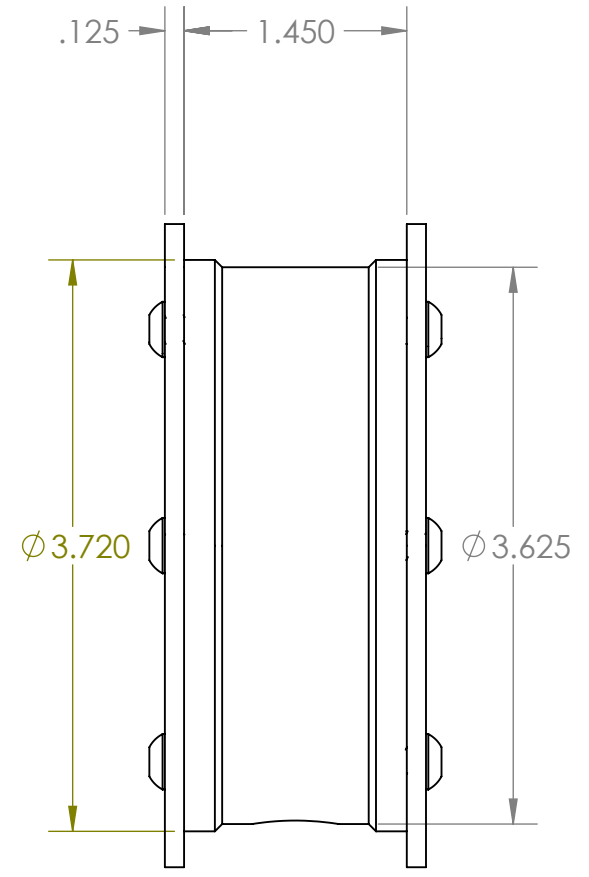
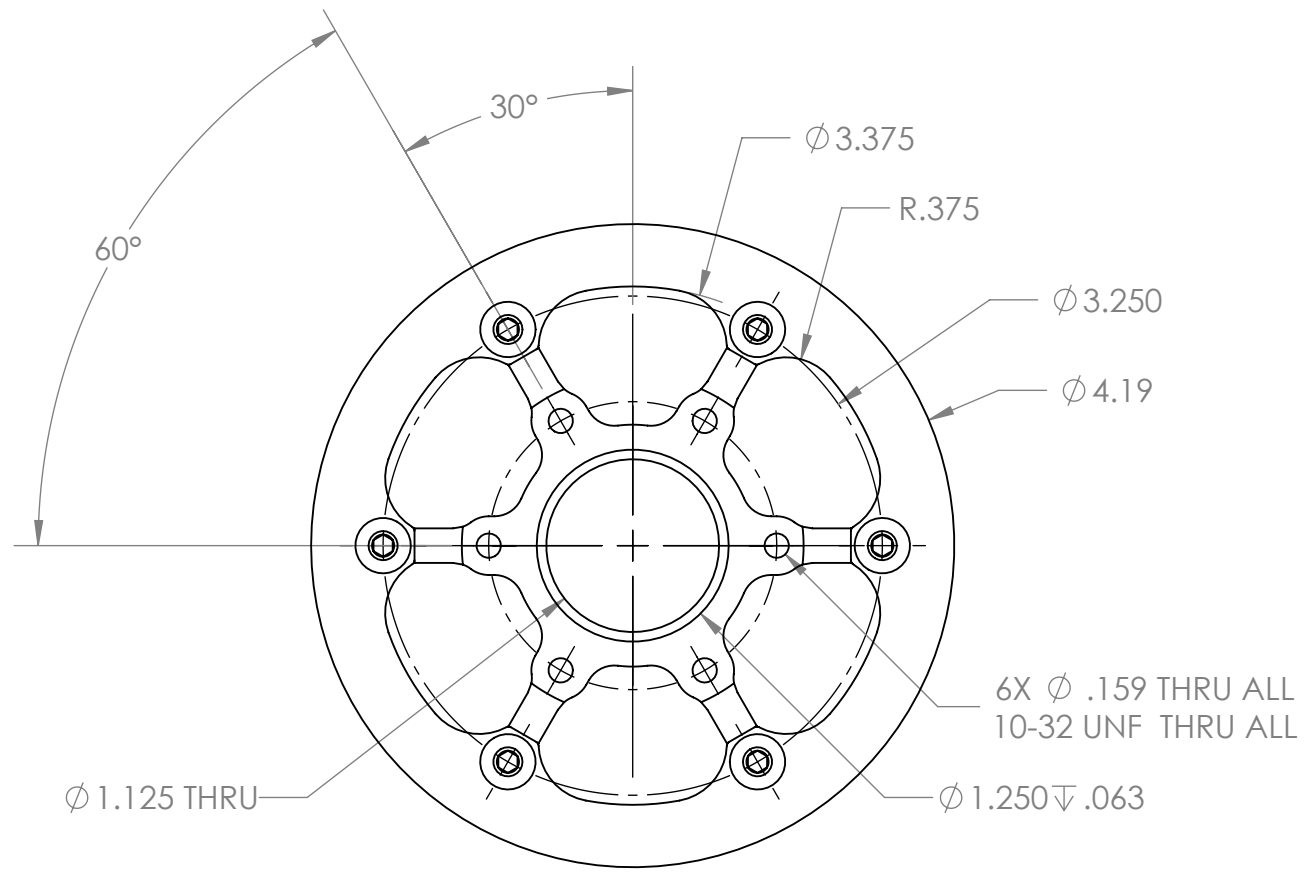

*** SEE CAD FOR ADDITIONAL TOOLPATH INFO***

UNLESS OTHERWISE SPECIFIED:		COMMENTS:			
DIMENSIONS ARE IN INCHES		DUAL DIMENSIONS ARE IN MILLIMETERS.			
TOLERANCES:		BREAK ALL SHARP EDGES.		TITLE:	
FRACTIONAL	±1/16			8IN HD PNEUMATIC WHEEL	
ANGULAR: MACH	±1°			HUB ASSEMBLY	
ANGULAR: BEND	±5°			1.125 BEARING BORE	
ONE PLACE DECIMAL	±0.1			SIZE	DWG. NO.
TWO PLACE DECIMAL	±0.01			B	am-3933
THREE PLACE DECIMAL	±0.005			REV	1
FOUR PLACE DECIMAL	±0.0005			SCALE: 1:1.25 SHEET 1 OF 1	
MATERIAL		CHECKED	NAME	DATE	
FINISH		ENG APPR.			
		MFG APPR.			
DO NOT SCALE DRAWING		Q.A.			

4

3

2

1

A

A

B

B