

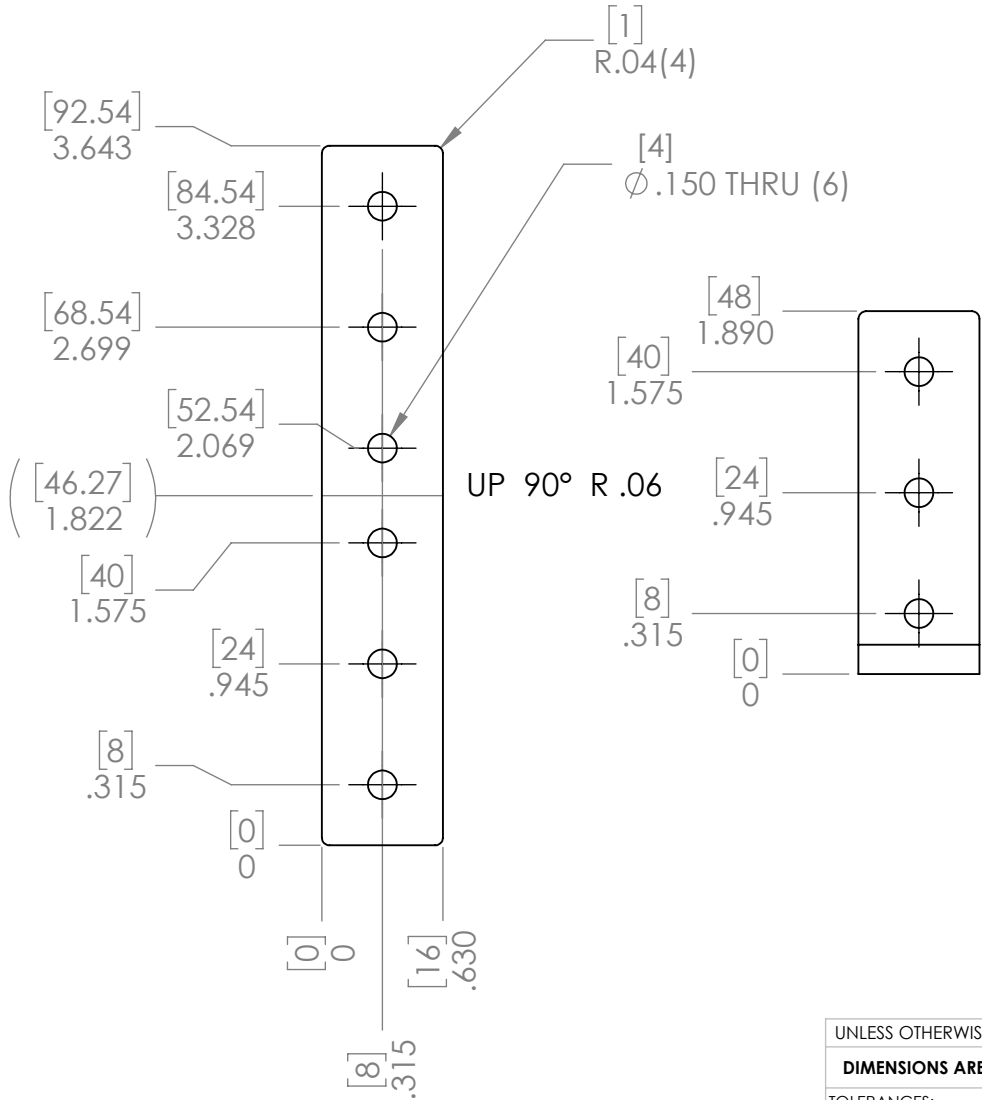

REVISION HISTORY			
REV.	DESCRIPTION	DATE	DRAWN BY
1	ORIGINAL PRINT	5/30/2017	B. HODSON
2	DRAWN TO MEET AMDS-1	5/14/2018	B. HODSON



*** SEE CAD FOR ADDITIONAL TOOLPATH INFO***

UNLESS OTHERWISE SPECIFIED:		COMMENTS:				
DIMENSIONS ARE IN INCHES		DUAL DIMENSIONS ARE IN MILLIMETERS.				
TOLERANCES:		BREAK ALL SHARP EDGES.		TITLE:		
FRACTIONAL	±1/16			CORNER GUSSET (S3 TUBE)		
ANGULAR: MACH	±1°					
ANGULAR: BEND	±5°					
ONE PLACE DECIMAL	±0.1					
TWO PLACE DECIMAL	±0.01			SIZE	DWG. NO.	REV
THREE PLACE DECIMAL	±0.005			A	am-3606	2
FOUR PLACE DECIMAL	±0.0005			SCALE: 1:1		SHEET 1 OF 1
MATERIAL	5052 ALUMINUM	CHECKED	NAME	DATE		
FINISH	TUMBLED	ENG APPR.	NL	5/16/18		
DO NOT SCALE DRAWING		MFG APPR.				
		Q.A.				