

REVISIONS HISTORY			
REV.	DESCRIPTION	DATE	DRAWN BY
1	ORIGINAL PRINT		A. BAKER
2	UPDATED TO AMDS-1	5/16/2018	A. MILLS

40T 20DP 14.5PA
GEARSTOCK
CLEAN CUT
NO BURRS BETWEEN TEETH

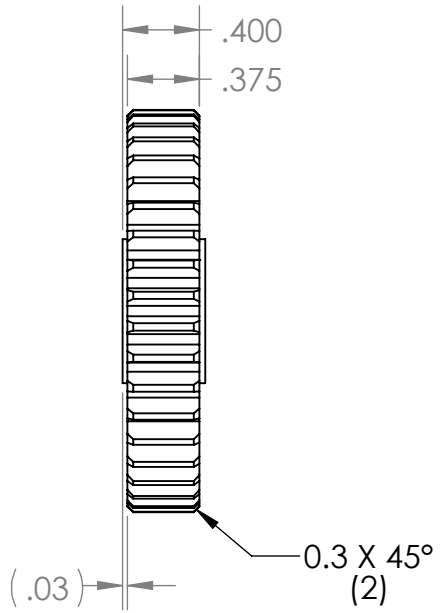

*** SEE CAD FOR ADDITIONAL TOOLPATH INFO***

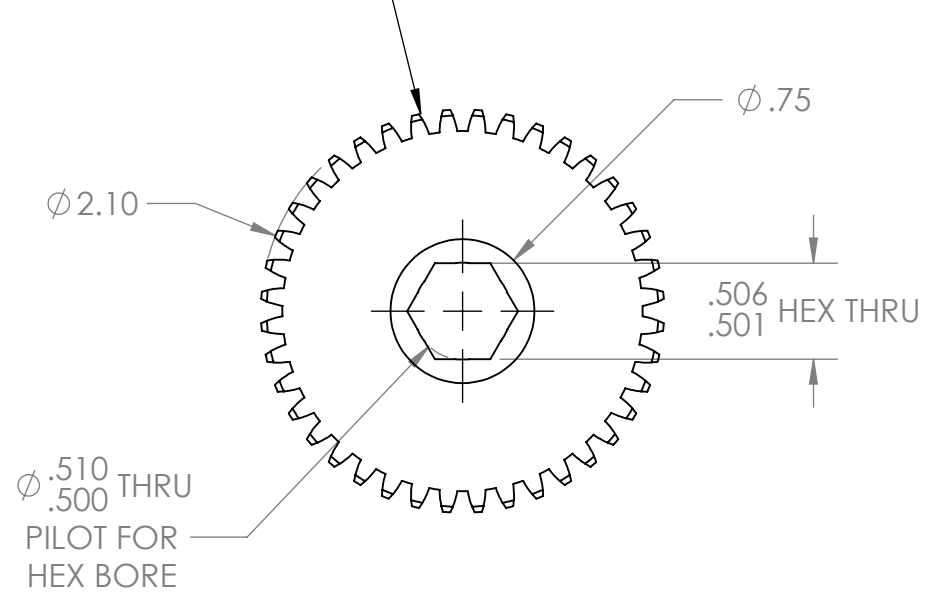
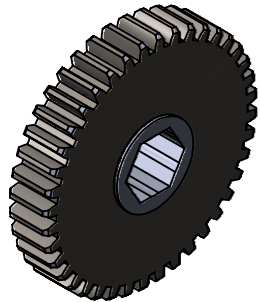

UNLESS OTHERWISE SPECIFIED:		COMMENTS:	
DIMENSIONS ARE IN INCHES		DUAL DIMENSIONS ARE IN MILLIMETERS.	
TOLERANCES:		BREAK ALL SHARP EDGES	
FRACTIONAL	$\pm 1/16$		
ANGULAR: MACH	$\pm 1^\circ$		
ANGULAR: BEND	$\pm 5^\circ$		
ONE PLACE DECIMAL	± 0.1		
TWO PLACE DECIMAL	± 0.01		
THREE PLACE DECIMAL	± 0.005		
FOUR PLACE DECIMAL	± 0.0005		
MATERIAL	4140 STEEL	NAME	DATE
FINISH	ZINC PLATED	CHECKED	NL 6/6/2018
		ENG APPR.	
		MFG APPR.	
DO NOT SCALE DRAWING		Q.A.	



TITLE:
**40T 20DP 14.5PA
 500IN HEX BORE GEAR**

SIZE	DWG. NO.	REV
A	am-0178	2
SCALE: 1:1	WEIGHT:	SHEET 1 OF 1