

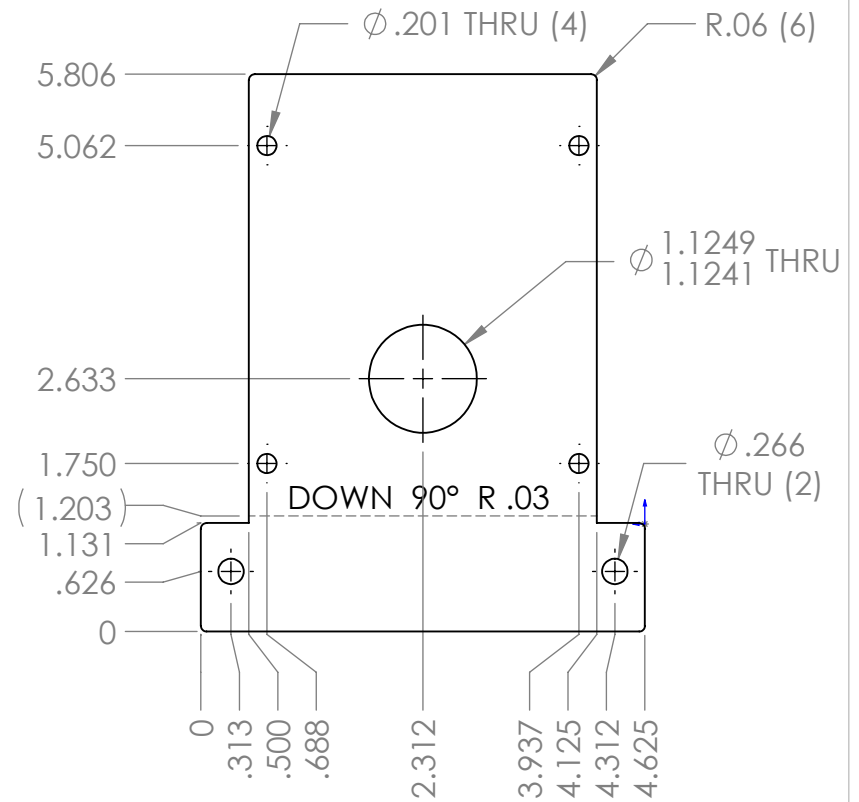

REVISION HISTORY			
REV.	DESCRIPTION	DATE	DRAWN BY
1	ORIGINAL PRINT	2/26/2011	M. KOORS
2	DRAWN TO MEET AMDS-1, TOLERANCES UPDATED	6/8/2018	A. SHORES

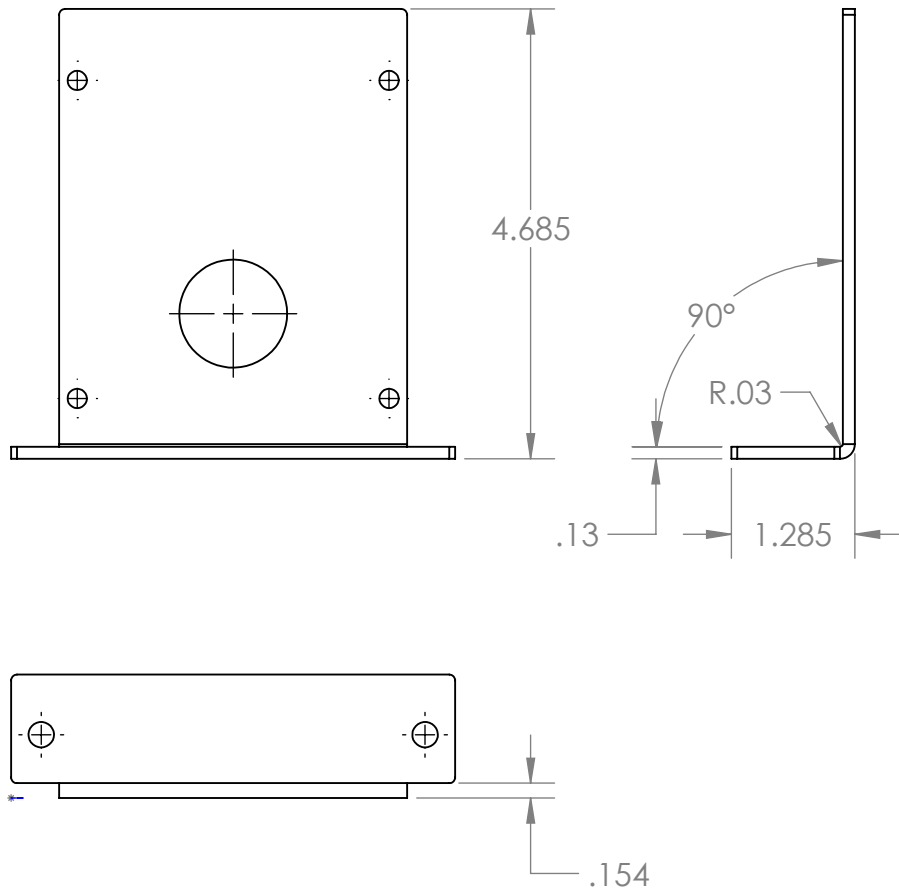

*** SEE CAD FOR ADDITIONAL TOOLPATH INFO***

UNLESS OTHERWISE SPECIFIED:		COMMENTS:				
DIMENSIONS ARE IN INCHES		DUAL DIMENSIONS ARE IN MILLIMETERS.				
TOLERANCES:		BREAK ALL SHARP EDGES		THICK OUTSIDE PLATE, WORMBOX		
FRACTIONAL	±1/16			SIZE	DWG. NO.	REV
ANGULAR: MACH	±1°			A	am-0919a	2
ANGULAR: BEND	±5°					
ONE PLACE DECIMAL	±0.1			SCALE: 1:2	WEIGHT:	SHEET 1 OF 1
TWO PLACE DECIMAL	±0.01					
THREE PLACE DECIMAL	±0.005					
FOUR PLACE DECIMAL	±0.0005					
MATERIAL		CHECKED	NAME	DATE		
5052 ALUMINUM		ENG APPR.	NL	7/3/18		
FINISH		MFG APPR.				
DEBURRED		Q.A.				
DO NOT SCALE DRAWING						