

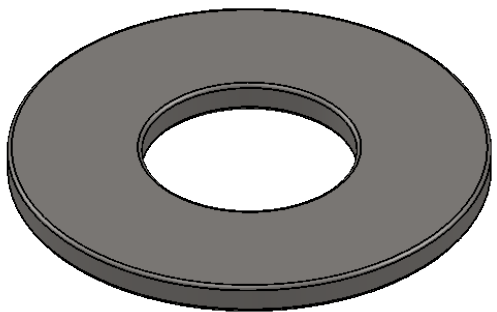

REVISION HISTORY			
REV.	DESCRIPTION	DATE	DRAWN BY
1	ORIGINAL PRINT	6/24/2014	R. BAKER
2	UPDATED TOLERANES	6/11/2018	B. HODSON

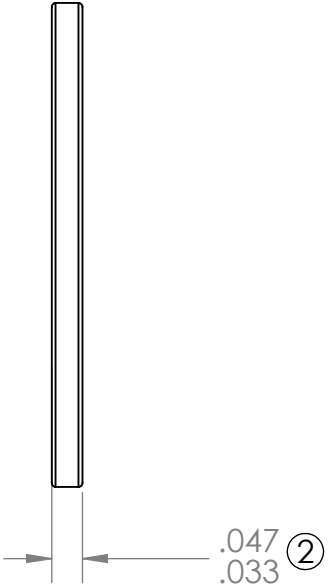
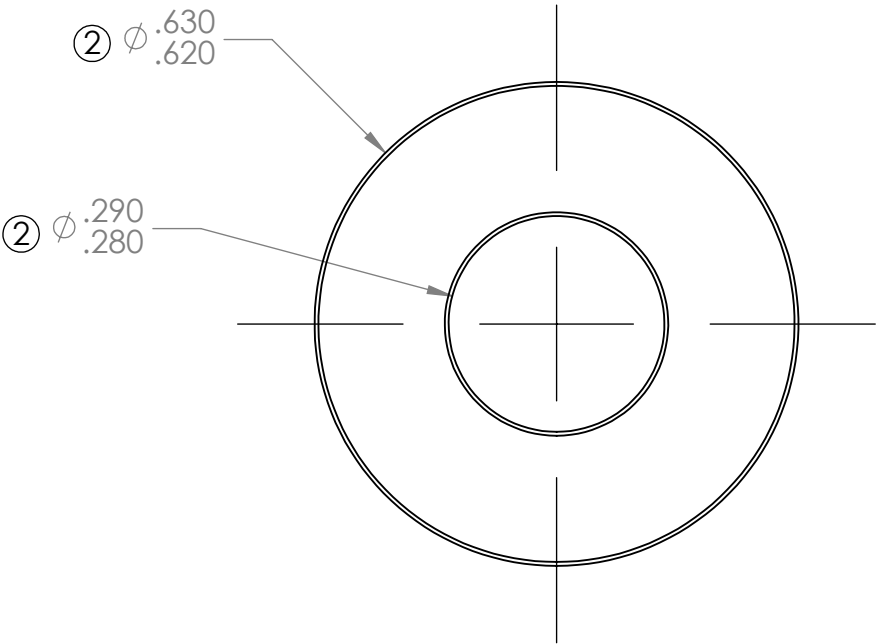

\*\*\* SEE CAD FOR ADDITIONAL TOOLPATH INFO\*\*\*

UNLESS OTHERWISE SPECIFIED:		COMMENTS:					
<b>DIMENSIONS ARE IN INCHES</b>		DUAL DIMENSIONS ARE IN MILLIMETERS.					
TOLERANCES: FRACTIONAL ±1/16 ANGULAR: MACH ±1° ANGULAR: BEND ±5° ONE PLACE DECIMAL ±0.1 TWO PLACE DECIMAL ±0.01 THREE PLACE DECIMAL ±0.005 FOUR PLACE DECIMAL ±0.0005		BREAK ALL SHARP EDGES		TITLE: <b>250ID FLAT WASHER</b>			
MATERIAL <b>STAINLESS STEEL</b>		CHECKED	NAME NL	DATE 6/12/18	SIZE <b>A</b>	DWG. NO. <b>am-1149</b>	REV <b>2</b>
FINISH <b>DEBURRED</b>		ENG APPR.		MFG APPR.		SCALE: 4:1 WEIGHT: SHEET 1 OF 1	
DO NOT SCALE DRAWING		Q.A.					