

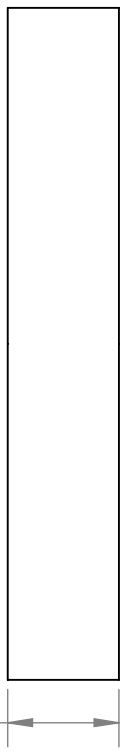

REVISION HISTORY			
REV.	DESCRIPTION	DATE	DRAWN BY
1	ORIGINAL PRINT	6/23/2014	R. BAKER
2	DRAWN TO MEET AMDS-1	6/25/2018	B. HODSON

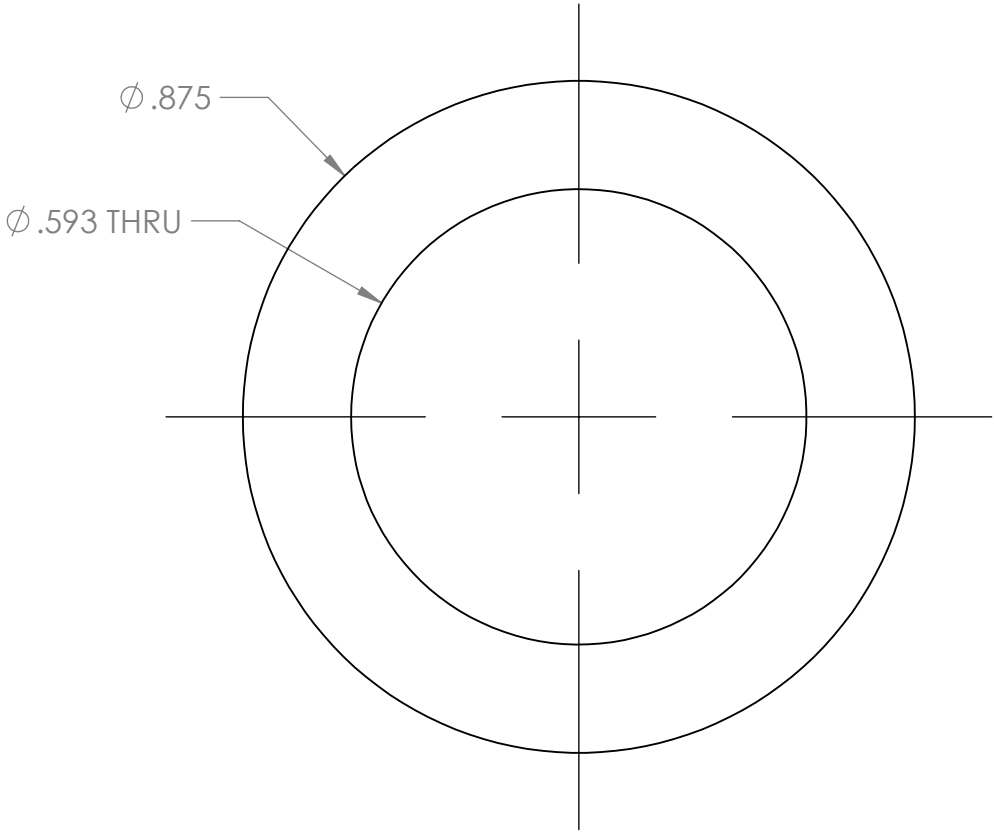
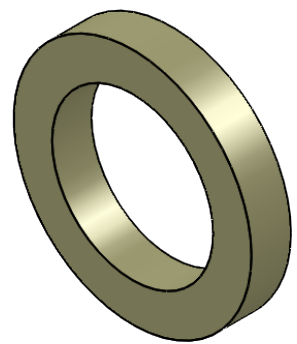

.145

\*\*\* SEE CAD FOR ADDITIONAL TOOLPATH INFO\*\*\*



UNLESS OTHERWISE SPECIFIED:		COMMENTS:				
<b>DIMENSIONS ARE IN INCHES</b>		DUAL DIMENSIONS ARE IN MILLIMETERS.				
TOLERANCES:		BREAK ALL SHARP EDGES		TITLE:		
FRACTIONAL	±1/16			593X875X145IN		
ANGULAR: MACH	±1°			SPACER		
ANGULAR: BEND	±5°			SIZE	DWG. NO.	REV
ONE PLACE DECIMAL	±0.1			<b>A</b>	am-1151	2
TWO PLACE DECIMAL	±0.01			SCALE: 4:1 WEIGHT:		
THREE PLACE DECIMAL	±0.005			SHEET 1 OF 1		
FOUR PLACE DECIMAL	±0.0005					
MATERIAL	NYLON	CHECKED	NAME	DATE		
FINISH	DEBURRED	ENG APPR.	NL	6/27/18		
DO NOT SCALE DRAWING		MFG APPR.	Q.A.			