

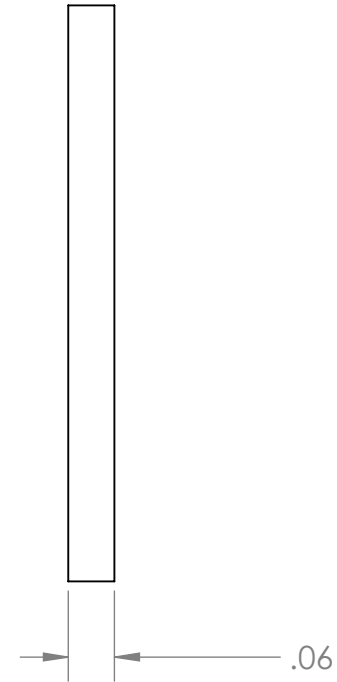

REVISION HISTORY			
REV.	DESCRIPTION	DATE	DRAWN BY
1	ORIGINAL PRINT	6/24/2014	R. BAKER
2	DRAWN TO MEET AMDS-1	6/25/2018	B. HODSON

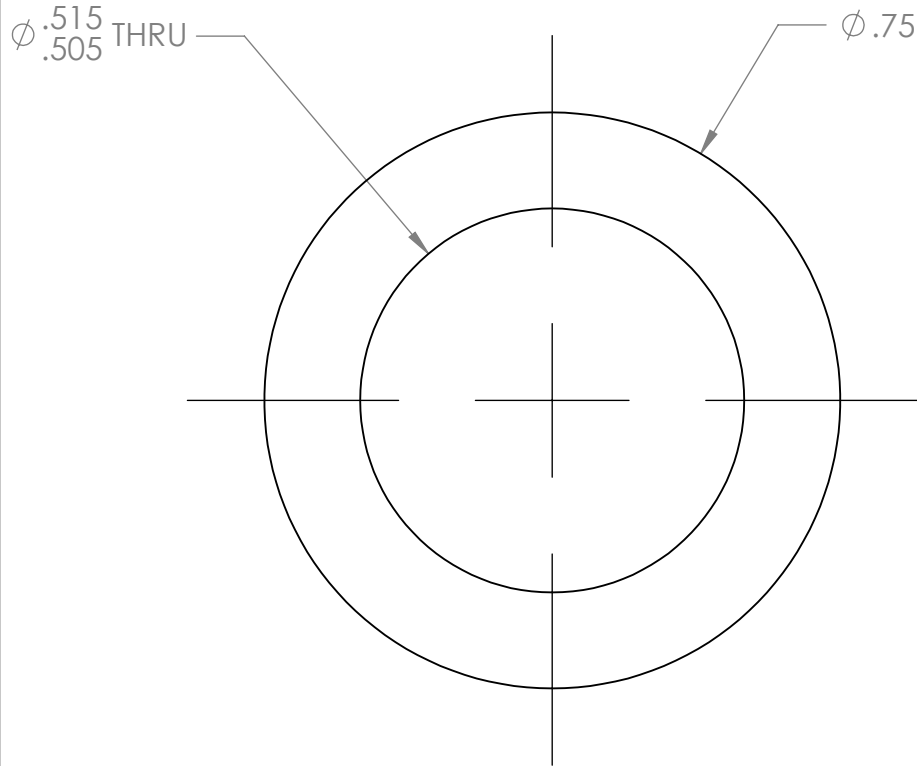

*** SEE CAD FOR ADDITIONAL TOOLPATH INFO***

UNLESS OTHERWISE SPECIFIED:		COMMENTS:				
DIMENSIONS ARE IN INCHES		DUAL DIMENSIONS ARE IN MILLIMETERS.				
TOLERANCES: FRACTIONAL ±1/16 ANGULAR: MACH ±1° ANGULAR: BEND ±5° ONE PLACE DECIMAL ±0.1 TWO PLACE DECIMAL ±0.01 THREE PLACE DECIMAL ±0.005 FOUR PLACE DECIMAL ±0.0005		BREAK ALL SHARP EDGES		500X750X060IN WASHER		
MATERIAL				SIZE	DWG. NO.	REV
BLACK NYLON				A	am-1221	2
FINISH						
DEBURRED						
DO NOT SCALE DRAWING		Q.A.		SCALE: 4:1	WEIGHT:	SHEET 1 OF 1

