

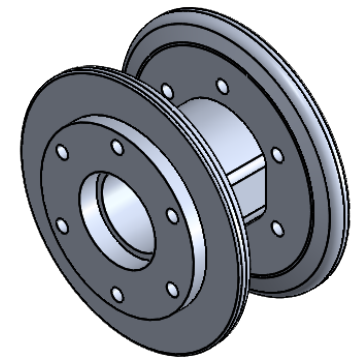

Rev	Discription of Changes
1	Production Print
1.2	Added detail and dimensions to cross section

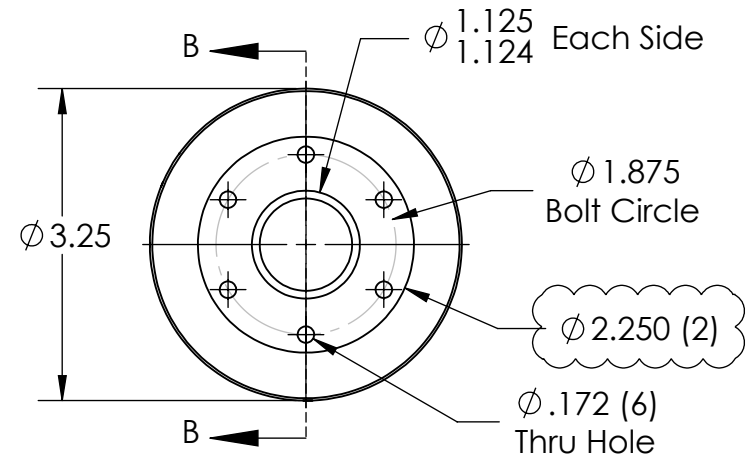

Use CAD for Part Geometry

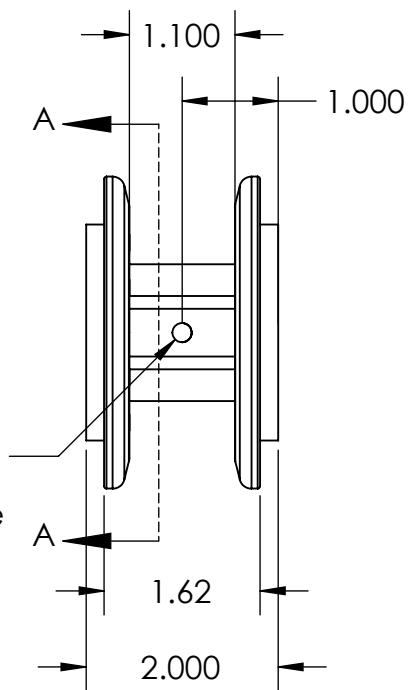
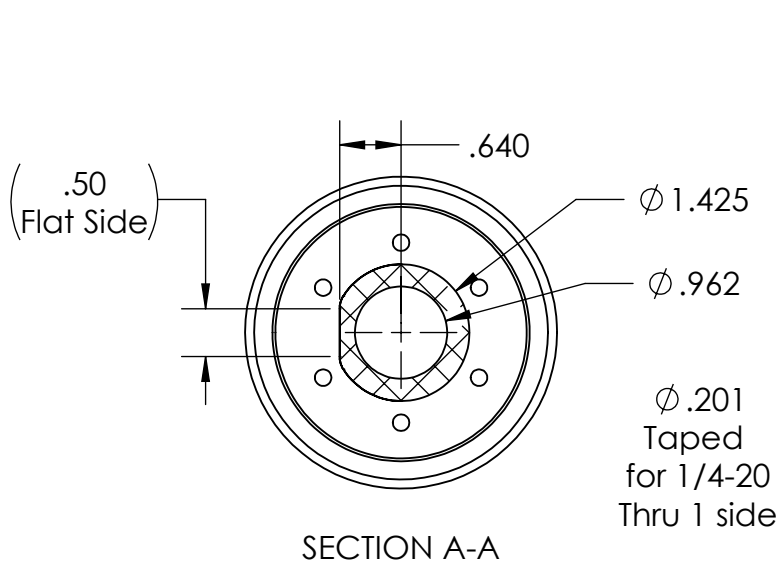
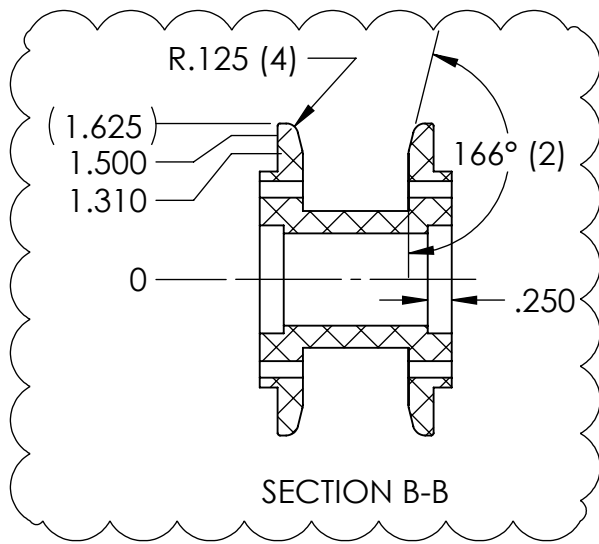

UNLESS OTHERWISE SPECIFIED:		NAME	DATE	
DIMENSIONS ARE IN INCHES		DRAWN	DB	
TOLERANCES:		CHECKED		
FRACTIONAL ±		ENG APPR.		
ANGULAR: MACH ± BEND ±5°		MFG APPR.		
TWO PLACE DECIMAL ±0.010		Q.A.		
THREE PLACE DECIMAL ±0.005		COMMENTS:		
INTERPRET GEOMETRIC TOLERANCING PER:				
MATERIAL				TITLE:
6061 Aluminum				Afterburner Winch Spool
FINISH				SIZE DWG. NO. REV
DEBURRED				A am-3348 1.2
DO NOT SCALE DRAWING				SCALE: 1:2 WEIGHT: SHEET 1 OF 1