

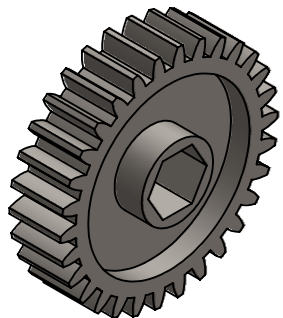

SECTION A-A

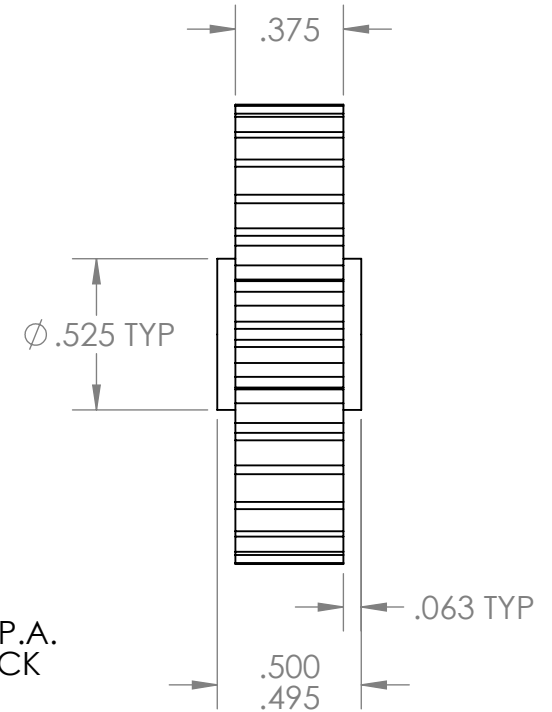
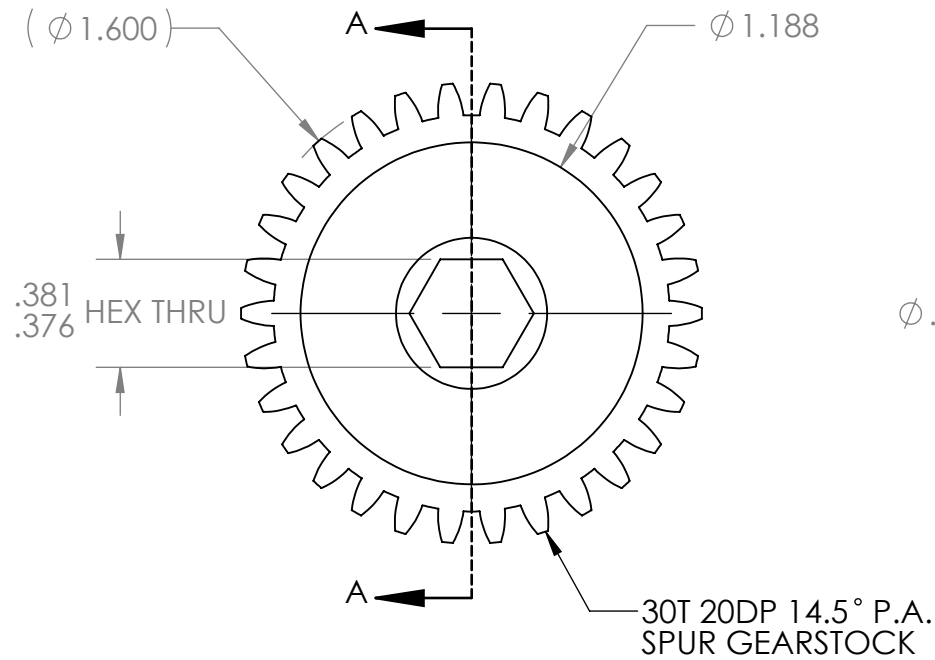

UNLESS OTHERWISE SPECIFIED:		NAME	DATE	
DIMENSIONS ARE IN INCHES		DRAWN	NL	
TOLERANCES:		CHECKED		TITLE:
FRACTIONAL $\pm 1/32$		ENG APPR.		30T 20DP 14.5° P.A.
ANGULAR: MACH $\pm 1^\circ$ BEND $\pm 5^\circ$		MFG APPR.		0.375 HEX BORE GEAR
ONE PLACE DECIMAL ± 0.1		Q.A.		SIZE DWG. NO. REV
TWO PLACE DECIMAL ± 0.01		COMMENTS:		A am-3536 1
THREE PLACE DECIMAL ± 0.005				SCALE: 1.5:1 WEIGHT: SHEET 1 OF 1
INTERPRET GEOMETRIC TOLERANCING PER:				
MATERIAL				
4140 STEEL				
FINISH				
ZINC PLATED				
DO NOT SCALE DRAWING				