

SECTION A-A

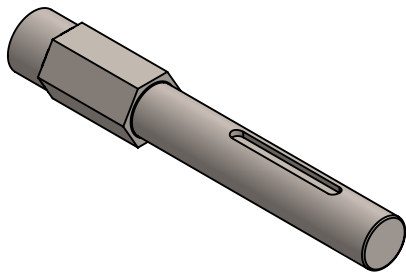

| UNLESS OTHERWISE SPECIFIED: | | NAME | DATE |
|--------------------------------------|--|-------------------------------------|------------|
| DIMENSIONS ARE IN INCHES | | DRAWN | KS 8/1/17 |
| TOLERANCES: | | CHECKED | NM 9/15/17 |
| FRACTIONAL ±1/32 | | ENG APPR. | |
| ANGULAR: MACH ±1° BEND ±5° | | MFG APPR. | |
| ONE PLACE DECIMAL ±0.1 | | Q.A. | |
| TWO PLACE DECIMAL ±0.01 | | COMMENTS: | |
| THREE PLACE DECIMAL ±0.005 | | DUAL DIMENSIONS ARE IN MILLIMETERS. | |
| INTERPRET GEOMETRIC TOLERANCING PER: | | | |
| MATERIAL | | | |
| 4140 STEEL | | | |
| FINISH | | | |
| ZINC PLATED | | | |
| DO NOT SCALE DRAWING | | | |

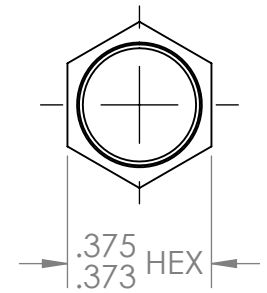
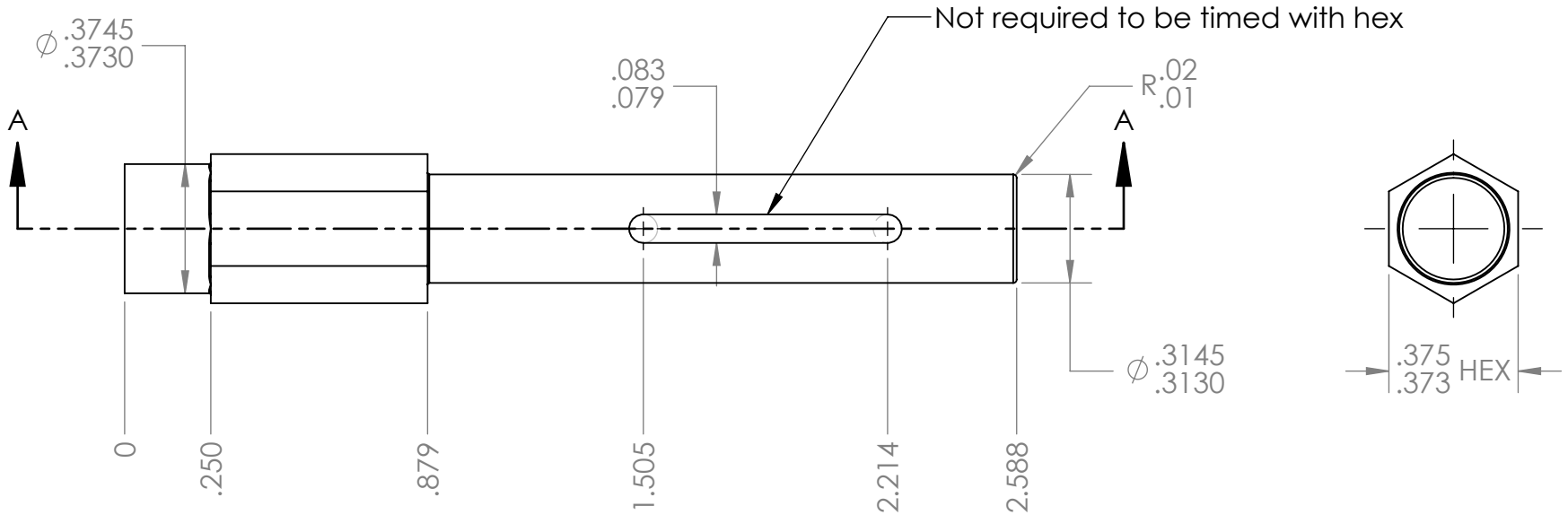

TITLE: DeCIMate OUTPUT SHAFT

| | | |
|----------|----------|-----|
| SIZE | DWG. NO. | REV |
| A | am-3695 | 1 |

SCALE: 2:1 WEIGHT: SHEET 1 OF 1