

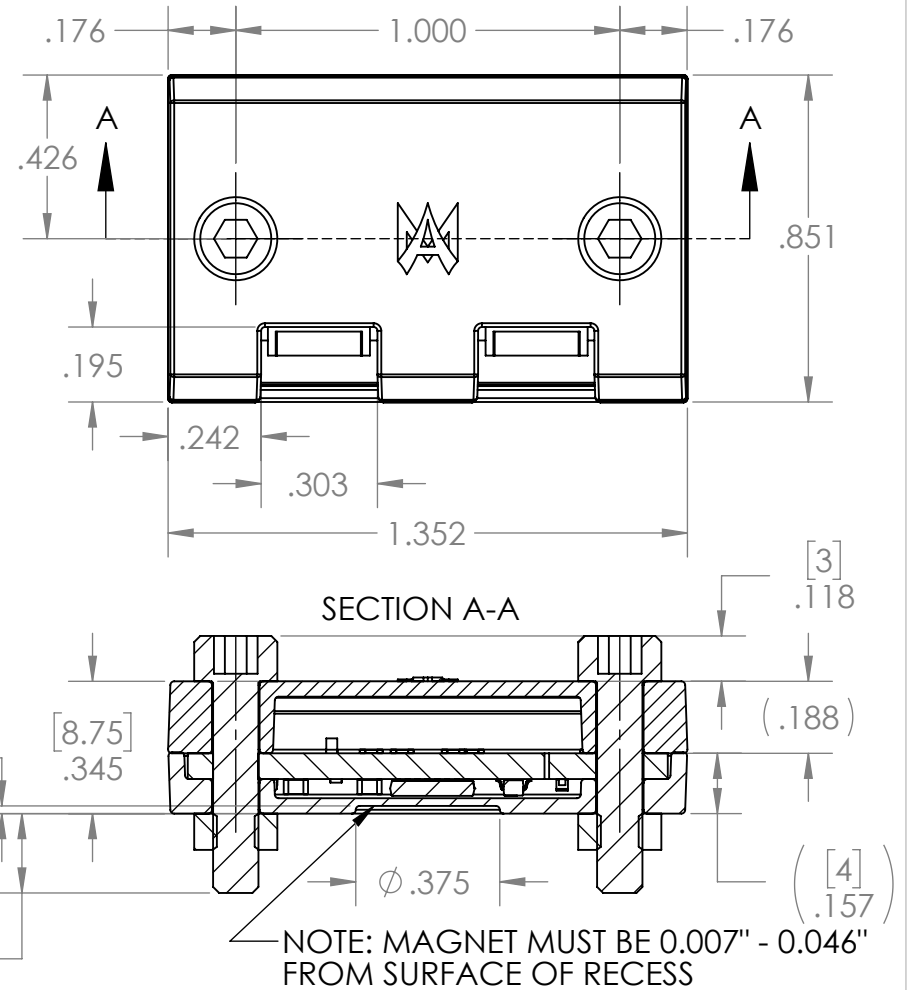

REVISION HISTORY			
REV.	DESCRIPTION	DATE	DRAWN BY
1	ORIGINAL PRINT	11/29/2017	N. LAWRENCE



UNLESS OTHERWISE SPECIFIED:		COMMENTS:				
DIMENSIONS ARE IN INCHES		DUAL DIMENSIONS ARE IN MILLIMETERS.				
TOLERANCES:		BREAK ALL SHARP EDGES.		TITLE:		
FRACTIONAL	±1/16			ANDYMARK		
ANGULAR: MACH	±1°			MAG ENCODER		
ANGULAR: BEND	±5°			SIZE		
ONE PLACE DECIMAL	±0.1			DWG. NO.		
TWO PLACE DECIMAL	±0.01			A am-3749		
THREE PLACE DECIMAL	±0.005			REV		
FOUR PLACE DECIMAL	±0.0005			1		
MATERIAL	ENCODER	NAME	DATE	SCALE: 2:1		
FINISH		CHECKED		SHEET 1 OF 1		
DO NOT SCALE DRAWING		ENG APPR.				
		MFG APPR.				
		Q.A.				