

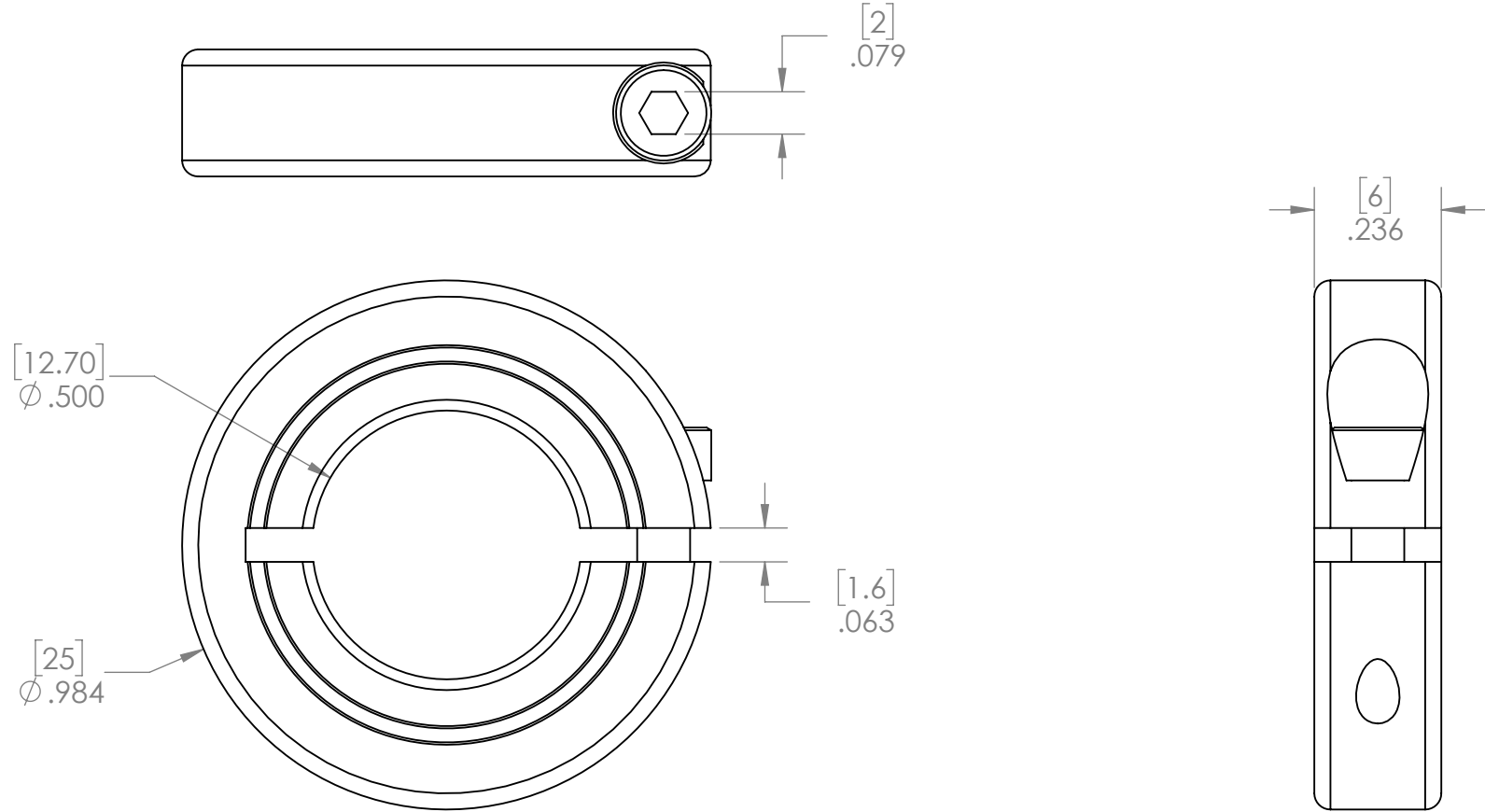

REVISION HISTORY			
REV.	DESCRIPTION	DATE	DRAWN BY
1	ORIGINAL PRINT	11/13/2017	N.MASSOUDA



\*\*\* SEE CAD FOR ADDITIONAL TOOLPATH INFO\*\*\*

UNLESS OTHERWISE SPECIFIED:		COMMENTS:				
<b>DIMENSIONS ARE IN INCHES</b>		DUAL DIMENSIONS ARE IN MILLIMETERS.				
TOLERANCES:		BREAK ALL SHARP EDGES.		TITLE:		
FRACTIONAL	±1/16			<b>1/2" ROUND THIN COLLAR CLAMP</b>		
ANGULAR: MACH	±1°					
ANGULAR: BEND	±5°					
ONE PLACE DECIMAL	±0.1					
TWO PLACE DECIMAL	±0.01	MATERIAL		CHECKED	NAME	DATE
THREE PLACE DECIMAL	±0.005	2024-T351 ALUMINIUM		ENG APPR.		
FOUR PLACE DECIMAL	±0.0005	FINISH		MFG APPR.		
BRIGHT		DO NOT SCALE DRAWING		Q.A.		
				SIZE	DWG. NO.	REV
				<b>A</b>	am-3792	1
				SCALE: 3:1	SHEET 1 OF 1	