

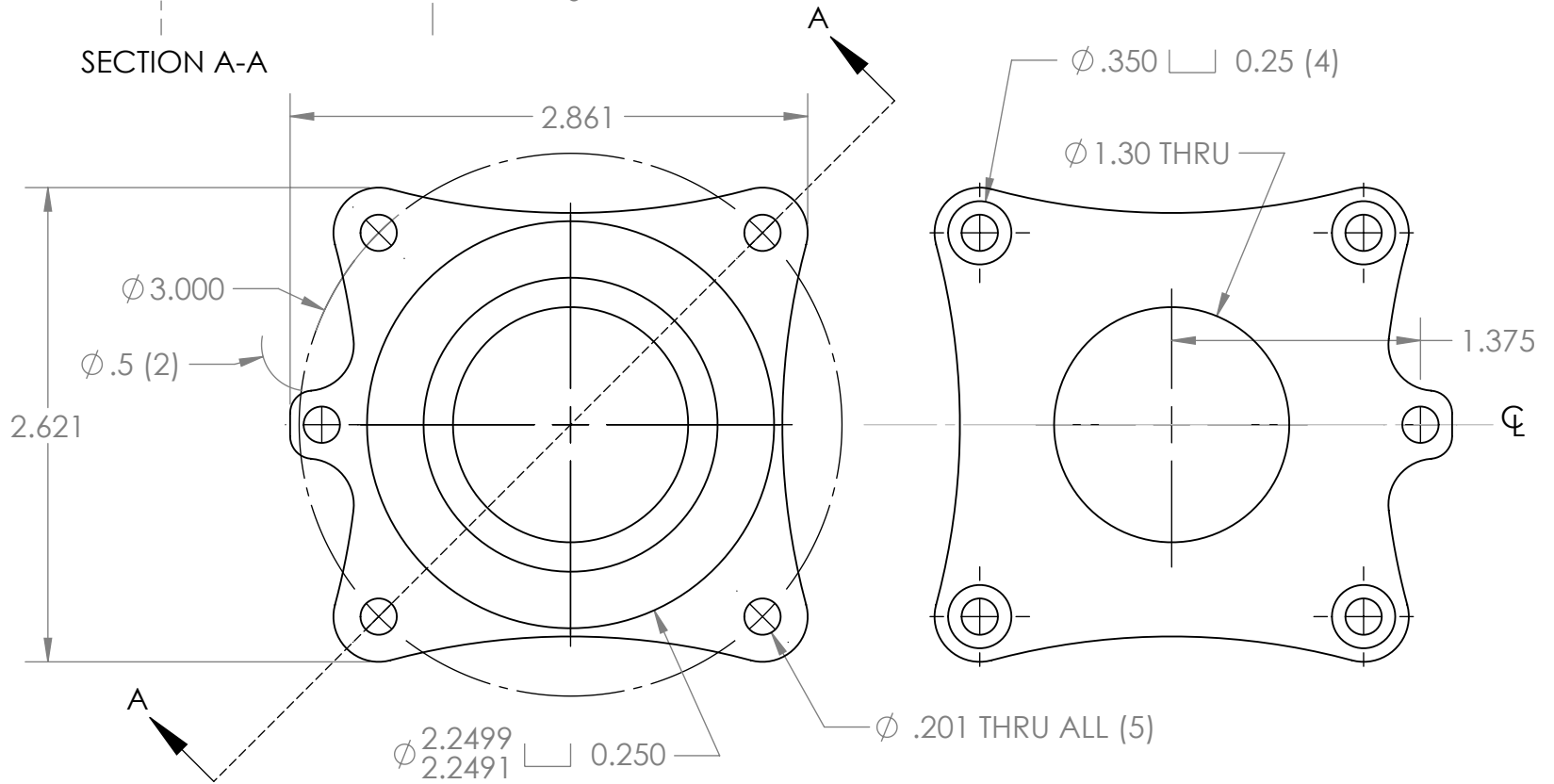

SECTION A-A

REVISION HISTORY			
REV.	DESCRIPTION	DATE	DRAWN BY
1	ORIGINAL PRINT	9/16/2014	A. BAKER
2	UPDATED TO AMDS-1	7/26/2018	A. MILLS
3	ADDED STEP FOR BEARING CLEARANCE	10/2/2018	N.MASSOUDA

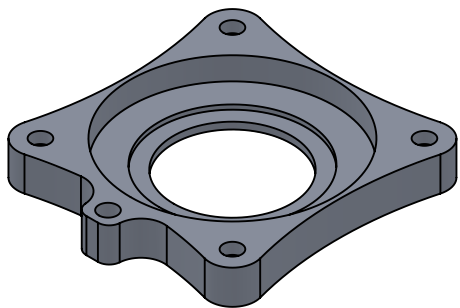

\*\*\* SEE CAD FOR ADDITIONAL TOOLPATH INFO\*\*\*



UNLESS OTHERWISE SPECIFIED:		COMMENTS:												
<b>DIMENSIONS ARE IN INCHES</b>		DUAL DIMENSIONS ARE IN MILLIMETERS.												
TOLERANCES:		BREAK ALL SHARP EDGES		TITLE:										
FRACTIONAL	±1/16	<table border="1"> <thead> <tr> <th>SIZE</th> <th>DWG. NO.</th> <th>REV</th> </tr> </thead> <tbody> <tr> <td><b>A</b></td> <td><b>am-3016a</b></td> <td><b>3</b></td> </tr> </tbody> </table>		SIZE	DWG. NO.	REV	<b>A</b>	<b>am-3016a</b>	<b>3</b>	<table border="1"> <tr> <td>SCALE: 1:1</td> <td>WEIGHT:</td> <td>SHEET 1 OF 1</td> </tr> </table>		SCALE: 1:1	WEIGHT:	SHEET 1 OF 1
SIZE	DWG. NO.			REV										
<b>A</b>	<b>am-3016a</b>			<b>3</b>										
SCALE: 1:1	WEIGHT:			SHEET 1 OF 1										
ANGULAR: MACH	±1°													
ANGULAR: BEND	±5°													
ONE PLACE DECIMAL	±0.1													
TWO PLACE DECIMAL	±0.01													
THREE PLACE DECIMAL	±0.005													
FOUR PLACE DECIMAL	±0.0005													
MATERIAL		NAME	DATE	SIZE										
6061-T6 ALUMINUM		CHECKED	NL	10/9/18										
FINISH		ENG APPR.												
TUMBLER		MFG APPR.												
DO NOT SCALE DRAWING		Q.A.												