

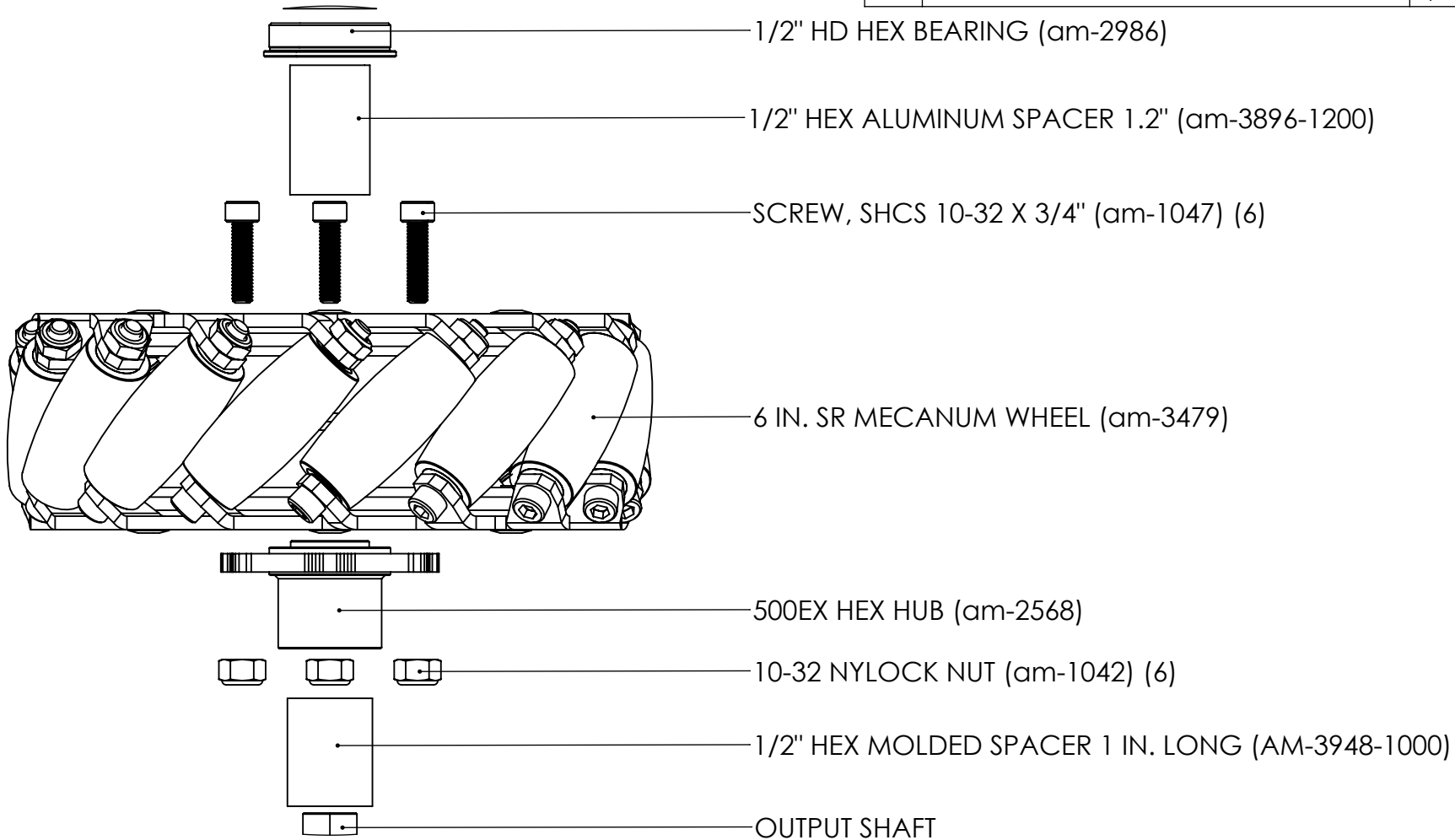

REVISION HISTORY			
REV.	DESCRIPTION	DATE	DRAWN BY
1	ORIGINAL PRINT	1/11/2019	N. MASSOUDA



UNLESS OTHERWISE SPECIFIED:		COMMENTS:				
DIMENSIONS ARE IN INCHES		DUAL DIMENSIONS ARE IN MILLIMETERS.				
TOLERANCES:		BREAK ALL SHARP EDGES		AM14U4 UPGRADE KIT		
FRACTIONAL	±1/16			6 IN. SR MECANUM		
ANGULAR: MACH	±1°			WHEEL DETAIL		
ANGULAR: BEND	±5°			SIZE DWG. NO. REV		
ONE PLACE DECIMAL	±0.1			A am-14U4_MK6 1		
TWO PLACE DECIMAL	±0.01			SCALE: 1:4 WEIGHT: SHEET 1 OF 2		
THREE PLACE DECIMAL	±0.005					
FOUR PLACE DECIMAL	±0.0005					
MATERIAL		NAME	DATE			
FINISH		CHECKED				
		ENG APPR.				
		MFG APPR.				
DO NOT SCALE DRAWING		Q.A.				

