

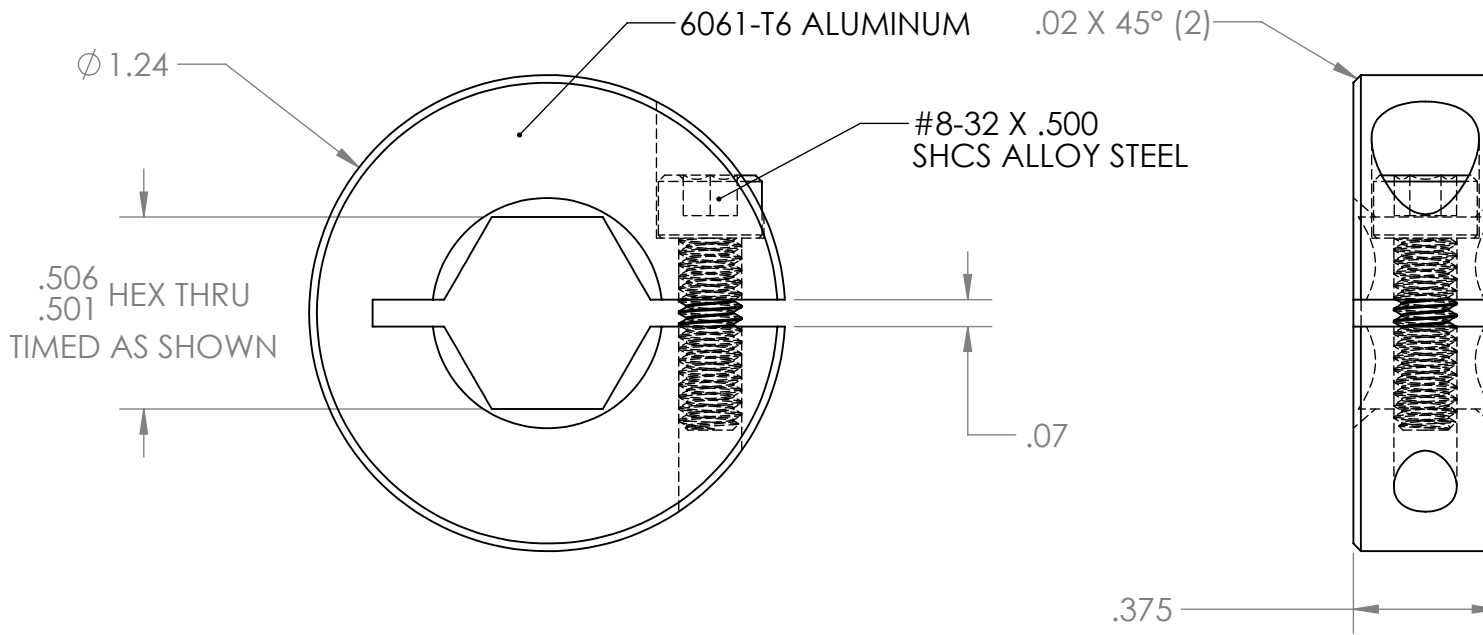

REVISION HISTORY			
REV.	DESCRIPTION	DATE	DRAWN BY
1	ORIGINAL PRINT	2/9/2013	A. BAKER
2	DRAWN TO MEET AMDS-1	6/25/2018	B. HODSON



\*\*\* SEE CAD FOR ADDITIONAL TOOLPATH INFO\*\*\*

UNLESS OTHERWISE SPECIFIED:		COMMENTS:				
<b>DIMENSIONS ARE IN INCHES</b>		DUAL DIMENSIONS ARE IN MILLIMETERS.				
TOLERANCES:		BREAK ALL SHARP EDGES		SIZE	DWG. NO.	REV
FRACTIONAL	±1/16			<b>A</b>	<b>am-1238</b>	<b>2</b>
ANGULAR: MACH	±1°					
ANGULAR: BEND	±5°					
ONE PLACE DECIMAL	±0.1					
TWO PLACE DECIMAL	±0.01					
THREE PLACE DECIMAL	±0.005					
FOUR PLACE DECIMAL	±0.0005					
MATERIAL		CHECKED	NAME	DATE		
FINISH		ENG APPR.	NL	7/3/18		
		MFG APPR.				
		Q.A.				
DO NOT SCALE DRAWING				SCALE: 2:1	WEIGHT:	SHEET 1 OF 1