

4

3

2

1

REVISION HISTORY			
REV.	DESCRIPTION	DATE	DRAWN BY
1	ORIGINAL PRINT	10/3/2019	N. LAWRENCE

B

B

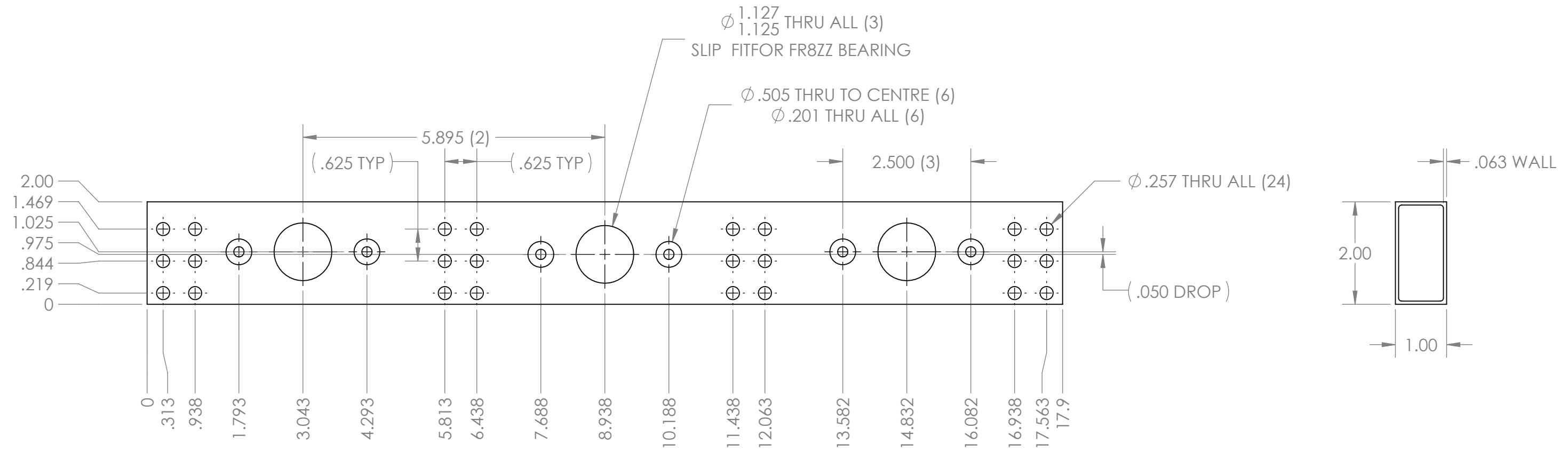

A

A

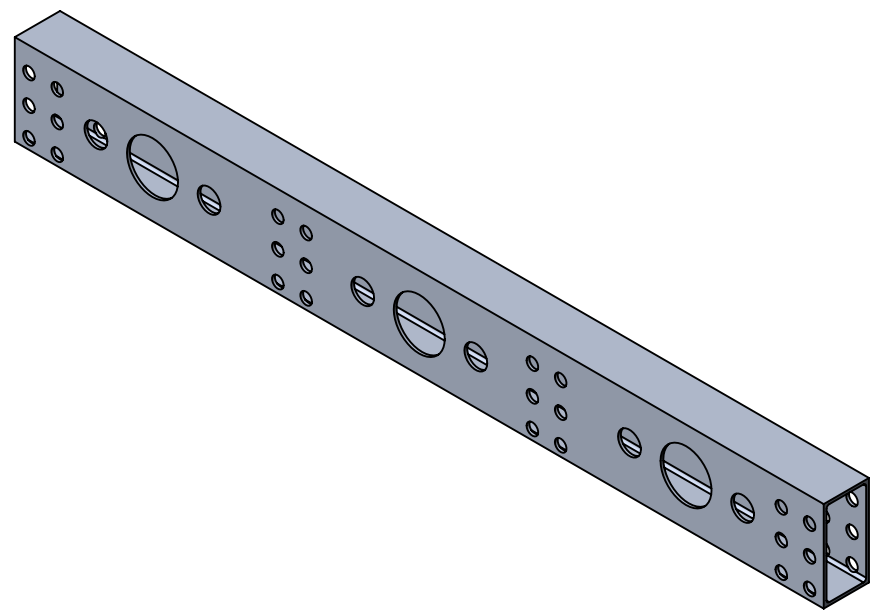

*** SEE CAD FOR ADDITIONAL TOOLPATH INFO***

UNLESS OTHERWISE SPECIFIED:		COMMENTS:			
DIMENSIONS ARE IN INCHES		DUAL DIMENSIONS ARE IN MILLIMETERS.			
TOLERANCES:		BREAK ALL SHARP EDGES.		TITLE:	
FRACTIONAL	$\pm 1/16$			ROVER	
ANGULAR: MACH	$\pm 1^\circ$			DRIVE RAIL	
ANGULAR: BEND	$\pm 5^\circ$			SIZE	DWG. NO.
ONE PLACE DECIMAL	± 0.1	CHECKED	NAME	A	am-4094
TWO PLACE DECIMAL	± 0.01	ENG APPR.	DATE	REV	1
THREE PLACE DECIMAL	± 0.005	MFG APPR.	10/3/19	SCALE: 1:2 SHEET 1 OF 1	
FOUR PLACE DECIMAL	± 0.0005	Q.A.			
MATERIAL	6061-T6 AL	DO NOT SCALE DRAWING			
FINISH	TUMBLER				

4

3

2

1