

REVISION HISTORY			
REV.	DESCRIPTION	DATE	DRAWN BY
1	ORIGINAL PRINT	9/4/2015	N. LAWRENCE
1.1	ADDED TABLE OF DUROMETERS	12/9/2015	N. LAWRENCE
2	REMOVED TABLE, UPDATED TO AMDS-1	9/4/2019	N. LAWRENCE
3	UPDATED DIMS	10/29/2019	K. KOLODZIEJ

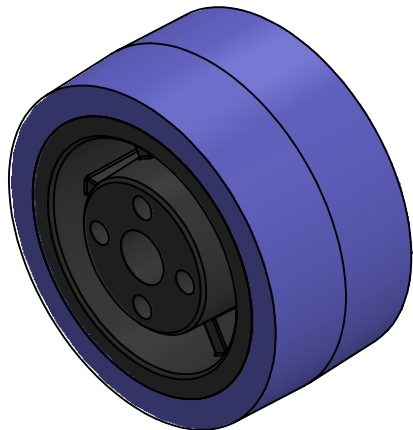
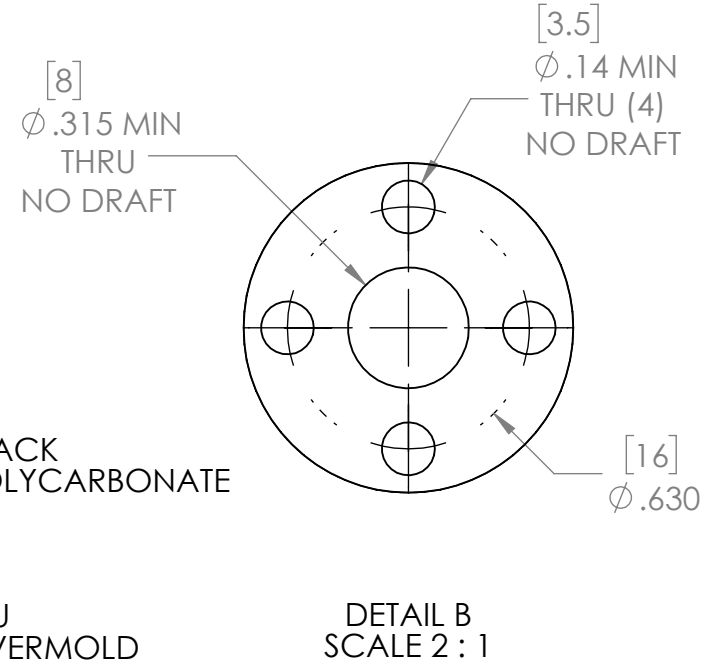
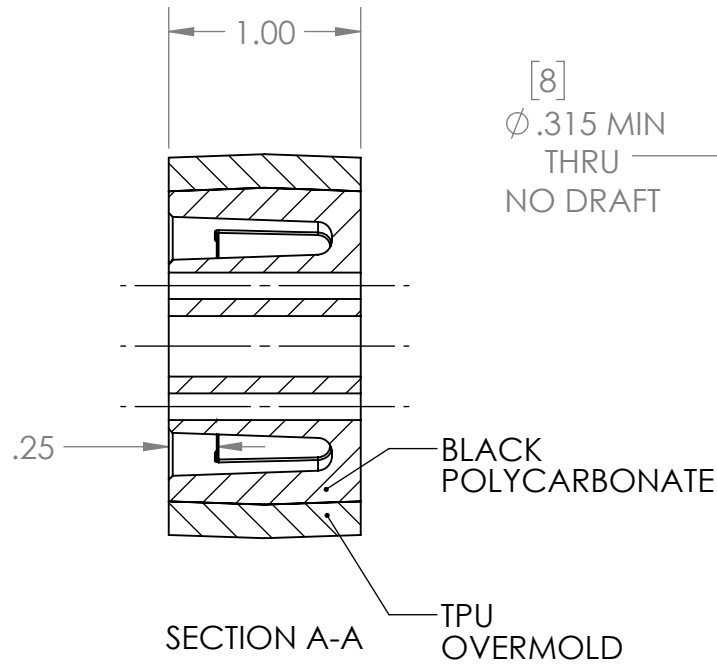
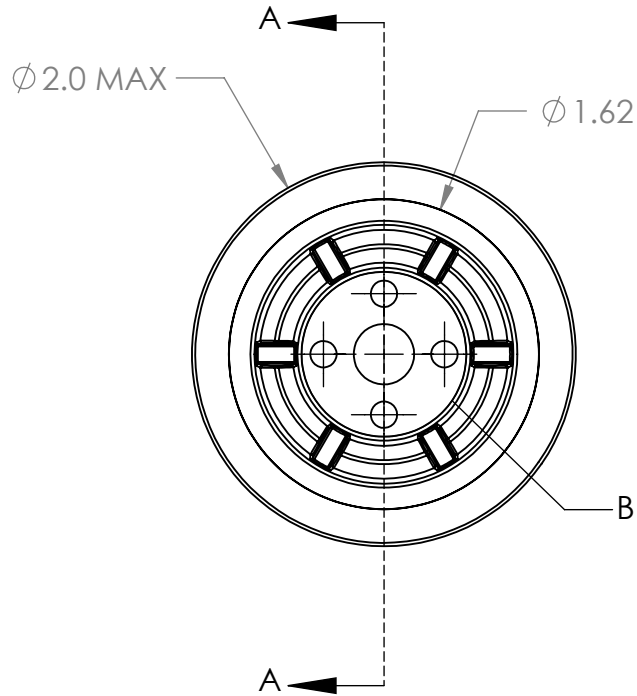

\*\*\* SEE CAD FOR ADDITIONAL TOOLPATH INFO\*\*\*

UNLESS OTHERWISE SPECIFIED:		COMMENTS:				
<b>DIMENSIONS ARE IN INCHES</b>		DUAL DIMENSIONS ARE IN MILLIMETERS.				
TOLERANCES:		BREAK ALL SHARP EDGES.		<b>SIZE</b> <b>A</b>	<b>DWG. NO.</b> am-3156	<b>REV</b> 3
FRACTIONAL	±1/16	2° DRAFT APPLIED TO MOST SURFACES UNLESS OTHERWISE NOTED.				
ANGULAR: MACH	±1°	CHECKED	NAME	DATE	<b>SHEET 1 OF 1</b>	
ANGULAR: BEND	±5°	ENG APPR.	NL	10/29/19		
ONE PLACE DECIMAL	±0.1	MFG APPR.				
TWO PLACE DECIMAL	±0.01	Q.A.				
THREE PLACE DECIMAL	±0.005					
FOUR PLACE DECIMAL	±0.0005					
MATERIAL	PC CORE TPU OVERMOLD					
FINISH	DEBURRED					
DO NOT SCALE DRAWING						