

REVISION HISTORY

REV.	DESCRIPTION	DATE	DRAWN BY
1	ORIGINAL PRINT	9/5/2018	N. LAWRENCE
2	REMOVED DRAFT, INCREASED DIAMETER	9/24/2018	N. LAWRENCE
3	ADDED am-3948-188	11/14/2018	N. LAWRENCE
4	ADDED am-3948-375	3/2/2020	N. LAWRENCE

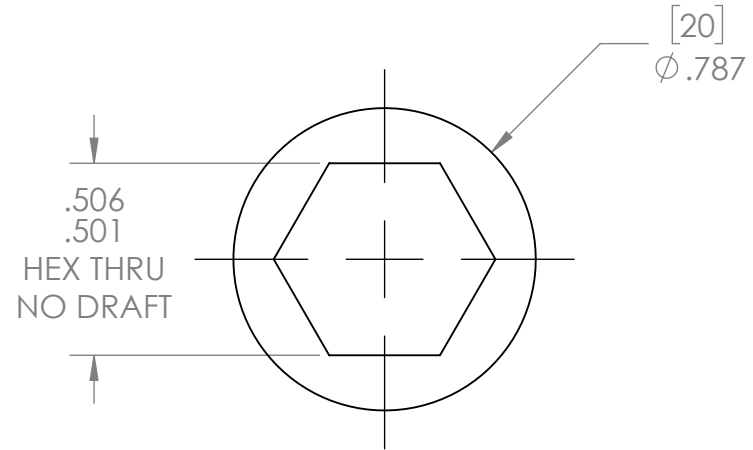
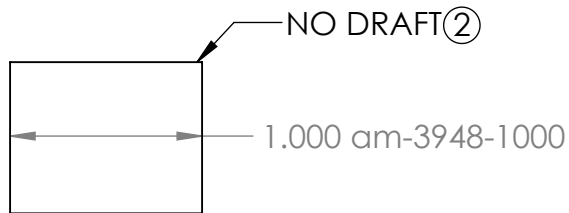
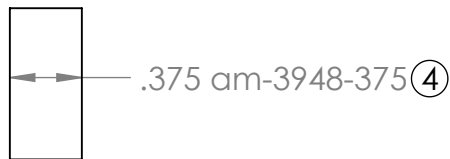
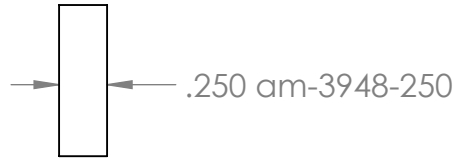
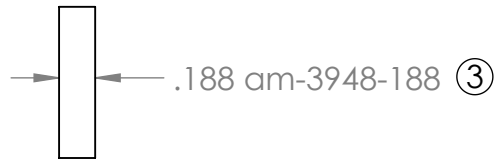
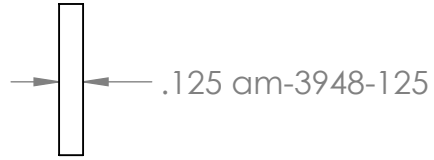
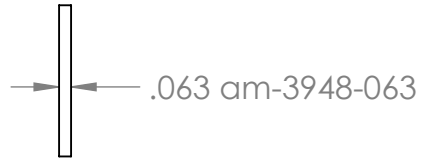

*** SEE CAD FOR ADDITIONAL TOOLPATH INFO***

UNLESS OTHERWISE SPECIFIED:		COMMENTS:				
DIMENSIONS ARE IN INCHES		DUAL DIMENSIONS ARE IN MILLIMETERS.				
TOLERANCES: FRACTIONAL ±1/16 ANGULAR: MACH ±1° ANGULAR: BEND ±5° ONE PLACE DECIMAL ±0.1 TWO PLACE DECIMAL ±0.01 THREE PLACE DECIMAL ±0.005 FOUR PLACE DECIMAL ±0.0005		BREAK ALL SHARP EDGES.		SIZE A DWG. NO. am-3948 REV 4		
MATERIAL BLACK PC		CHECKED	NAME KK			
FINISH DEBURRED		ENG APPR.				
DO NOT SCALE DRAWING		MFG APPR.				
		Q.A.				