

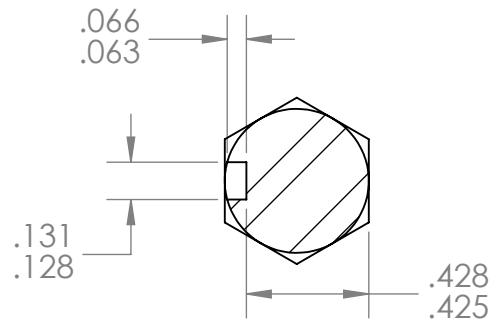

REVISIONS			
REV.	DESCRIPTION	DATE	DRAWN
2	PREVIOUS PRINT	10/12/2010	A. BAKER
3	REMOVED ENCODER STUD, ADDED DOWEL HOLE FOR MAGNET	10/20/2016	N. LAWRENCE
4	UPDATED DEPTH OF DOWEL DEPTH FROM 0.500" TO 0.557"	11/4/2016	N. LAWRENCE
5	ADDED MAGNET, CHANGED TO AM-0740A	2/1/2017	N.MASSOUDA
6	DRAWN TO MEET AMDS-1, TOLERANCES UPDATED	6/4/2018	A. SHORES

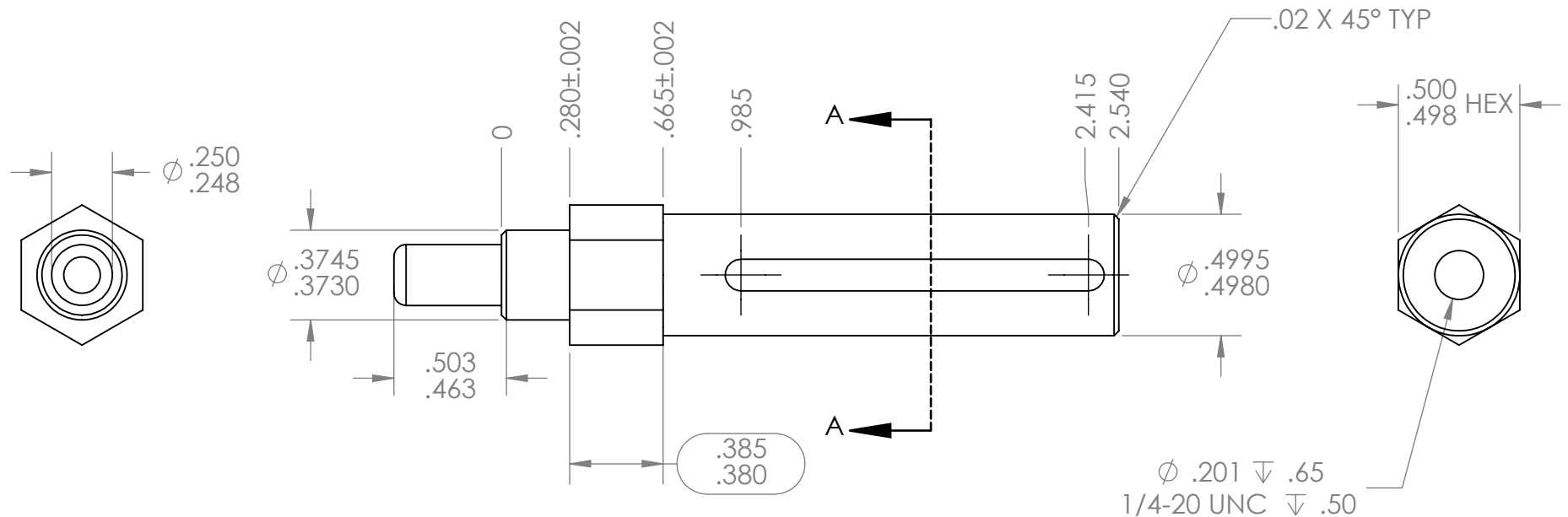

SECTION A-A
SCALE 1.5 : 1

*** SEE CAD FOR ADDITIONAL TOOLPATH INFO***

UNLESS OTHERWISE SPECIFIED:		COMMENTS:			
DIMENSIONS ARE IN INCHES		DUAL DIMENSIONS ARE IN MILLIMETERS.			
TOLERANCES:		BREAK ALL SHARP EDGES		TITLE:	
FRACTIONAL	±1/16			CIMPLE BOX/ SPIN BOX	
ANGULAR: MACH	±1°			OUTPUT SHAFT	
ANGULAR: BEND	±5°			SIZE	
ONE PLACE DECIMAL	±0.1			DWG. NO.	
TWO PLACE DECIMAL	±0.01			REV	
THREE PLACE DECIMAL	±0.005			A am-0740a 6	
FOUR PLACE DECIMAL	±0.0005			SCALE: 1:1	
MATERIAL	4140 STEEL	NAME	DATE	WEIGHT:	
FINISH	ZINC PLATED	CHECKED	NL 6/29/18	SHEET 1 OF 1	
DO NOT SCALE DRAWING		ENG APPR.			
		MFG APPR.			
		Q.A.			