

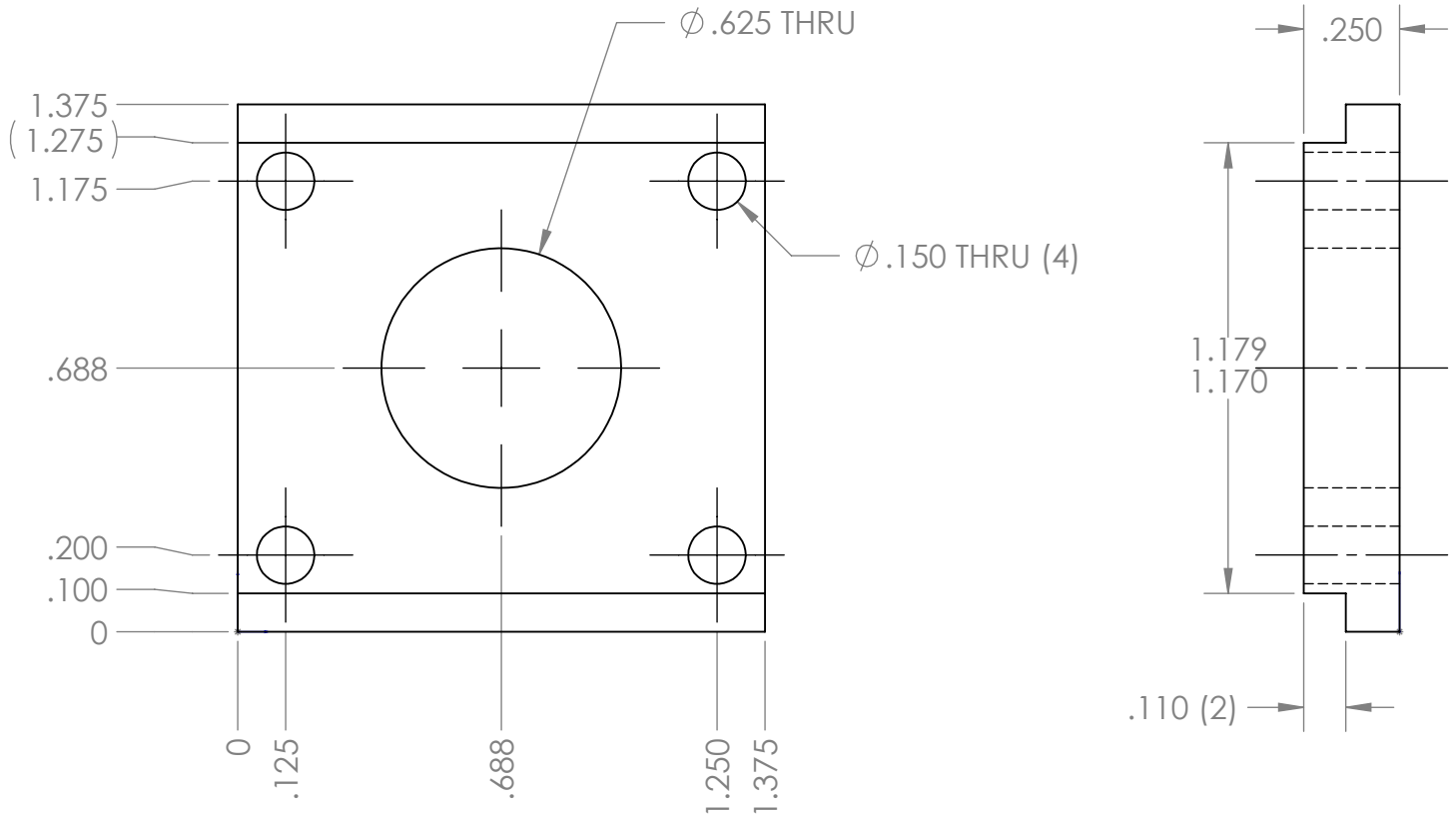

REVISION HISTORY			
REV.	DESCRIPTION	DATE	DRAWN BY
1	ORIGINAL PRINT	10/26/2010	D. RICHARDSON
2	DRAWN TO MEET AMDS-1, TOLERANCES UPDATED	6/20/2018	A. SHORES

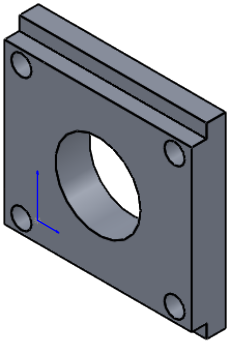

*** SEE CAD FOR ADDITIONAL TOOLPATH INFO***



UNLESS OTHERWISE SPECIFIED:		COMMENTS:					
DIMENSIONS ARE IN INCHES		DUAL DIMENSIONS ARE IN MILLIMETERS.					
TOLERANCES:		BREAK ALL SHARP EDGES		TITLE:			
FRACTIONAL	±1/16			STANDARD THRU BLOCK			
ANGULAR: MACH	±1°			FOR MODULOX			
ANGULAR: BEND	±5°						
ONE PLACE DECIMAL	±0.1			SIZE	DWG. NO.	REV	
TWO PLACE DECIMAL	±0.01			A	am-0861	2	
THREE PLACE DECIMAL	±0.005						
FOUR PLACE DECIMAL	±0.0005						
MATERIAL	6061-T6 ALUMINUM	CHECKED	NAME	DATE			
FINISH	TUMBLER	ENG APPR.	NL	6/29/18			
		MFG APPR.					
DO NOT SCALE DRAWING		Q.A.			SCALE: 2:1	WEIGHT:	SHEET 1 OF 1