

REVISION HISTORY			
REV.	DESCRIPTION	DATE	DRAWN BY
1	ORIGINAL PRINT	10/3/2018	N.MASSOUDA
2	INCREASED SIZE OF HOLES AND BOSS	5/17/2019	N.MASSOUDA

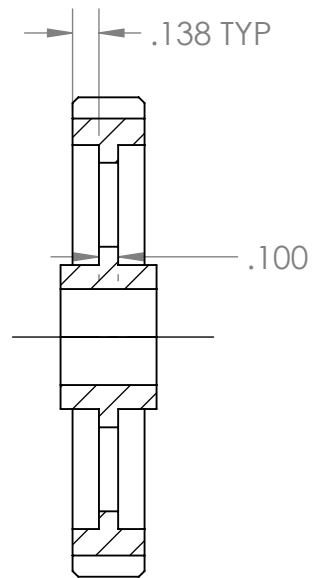

SECTION A-A

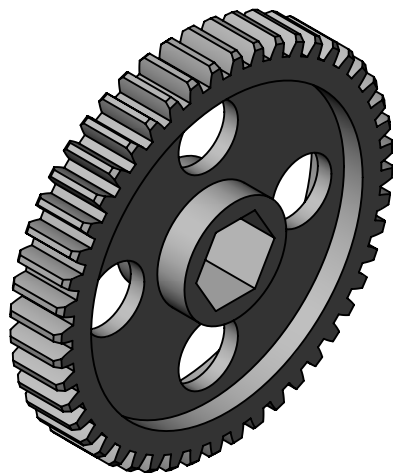
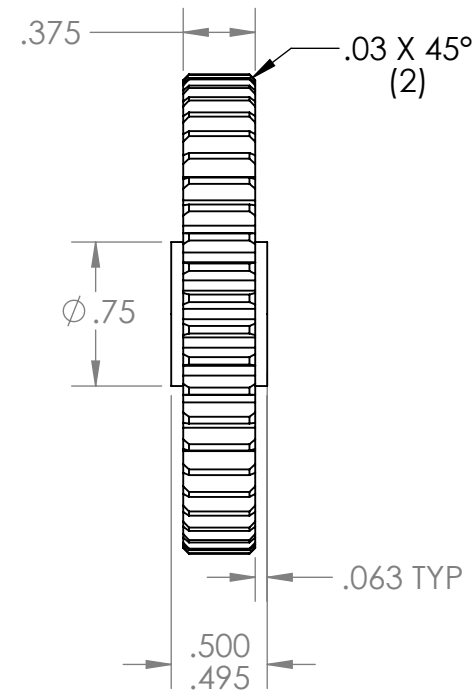
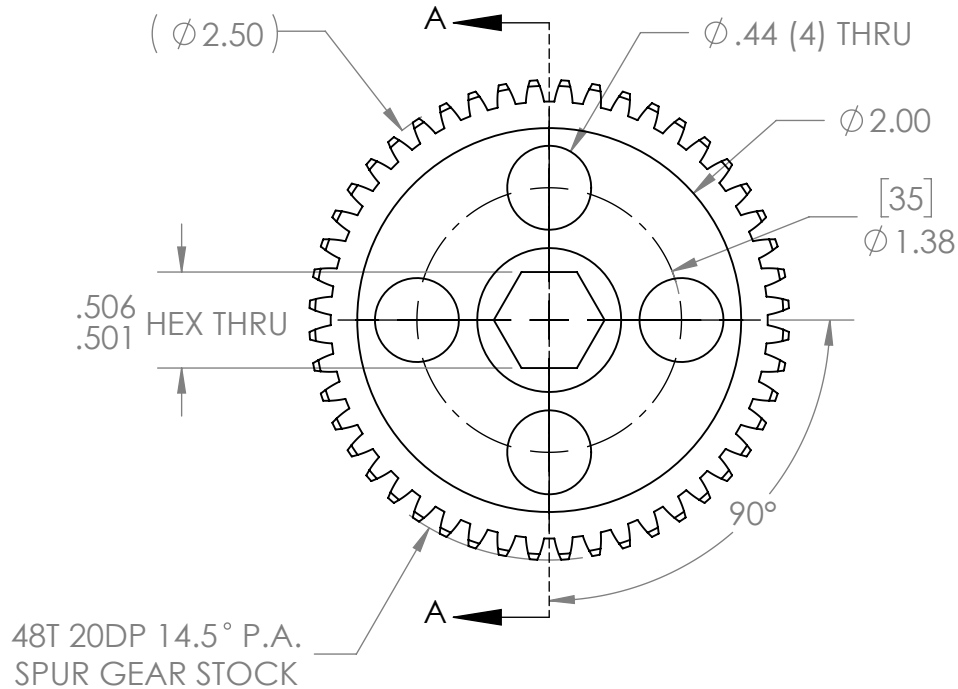

NO CIRCULAR TIMING OF HOLE PATTERN OR HEX REQUIRED

*** SEE CAD FOR ADDITIONAL TOOLPATH INFO***

UNLESS OTHERWISE SPECIFIED:		COMMENTS:				
DIMENSIONS ARE IN INCHES		DUAL DIMENSIONS ARE IN MILLIMETERS.				
TOLERANCES:		BREAK ALL SHARP EDGES		48T 20DP 14.5PA		
FRACTIONAL	±1/16			.500IN HEX BORE GEAR		
ANGULAR: MACH	±1°			WITH PG ACCESS HOLES		
ANGULAR: BEND	±5°			SIZE	DWG. NO.	REV
ONE PLACE DECIMAL	±0.1			A	am-4056	2
TWO PLACE DECIMAL	±0.01			SCALE: 1:1 WEIGHT: SHEET 1 OF 1		
THREE PLACE DECIMAL	±0.005					
FOUR PLACE DECIMAL	±0.0005					
MATERIAL	6061-T6 AL	CHECKED	NAME	DATE		
FINISH	NITUFF ANODIZED	ENG APPR.	NL	10/9/18		
DO NOT SCALE DRAWING		MFG APPR.				
		Q.A.				