

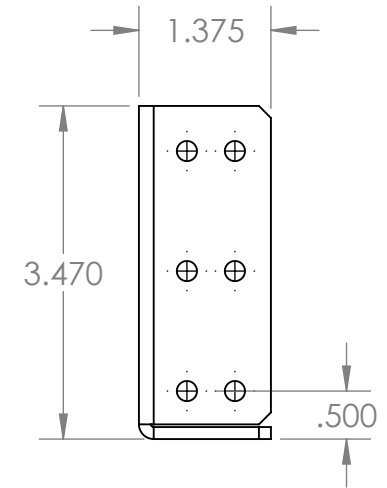

REVISIONS			
REV.	DESCRIPTION	DATE	DRAWN
1	ORIGINAL PRINT	9/29/2015	N. LAWRENCE
2	UPDATED NAME TO BE MORE GENERIC, AMDS-1	3/24/2020	N. LAWRENCE

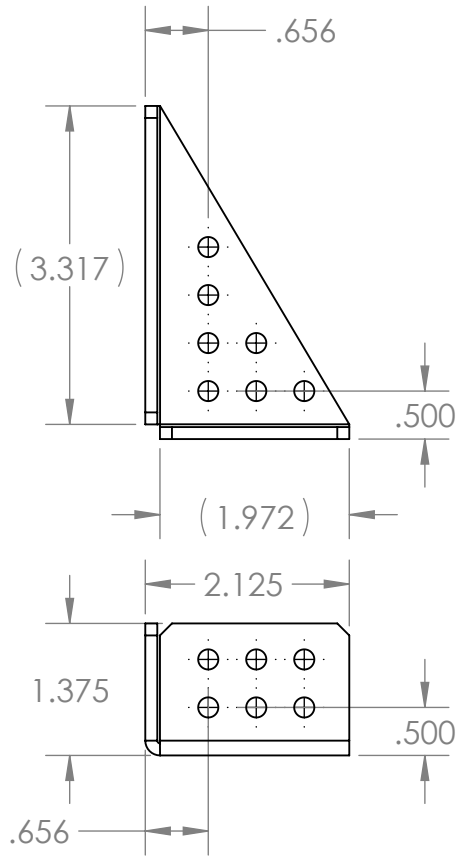

*** SEE CAD FOR ADDITIONAL TOOLPATH INFO***

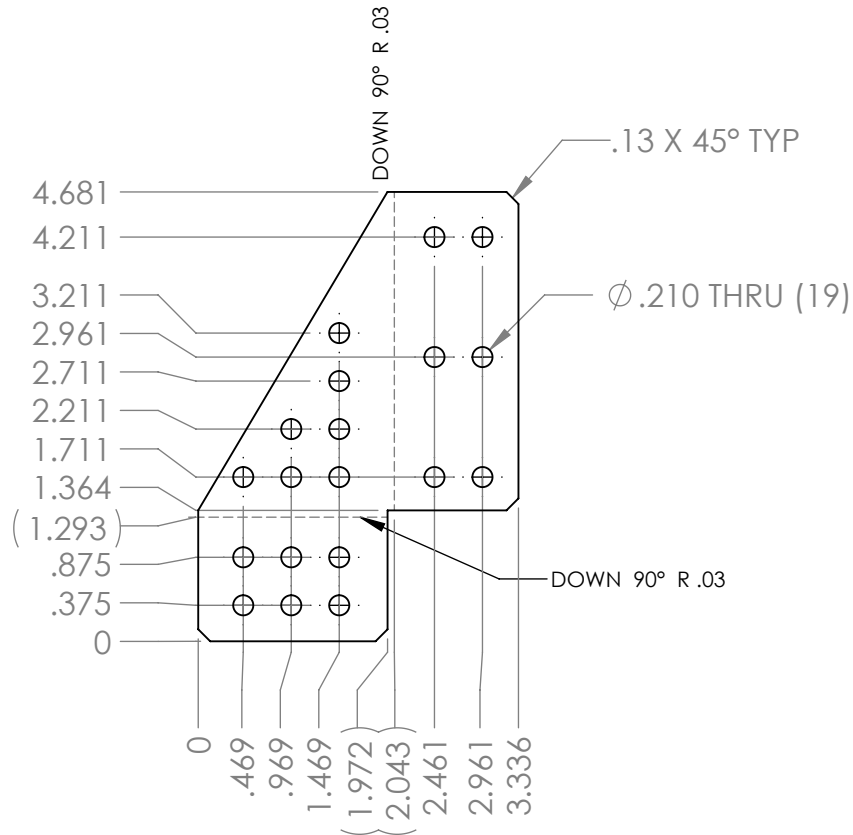
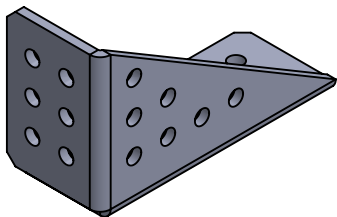

UNLESS OTHERWISE SPECIFIED:		COMMENTS:				
DIMENSIONS ARE IN INCHES		DUAL DIMENSIONS ARE IN MILLIMETERS.				
TOLERANCES:		BREAK ALL SHARP EDGES		TITLE:		
FRACTIONAL	±1/16			RIGHT TRIANGLE BRACKET		
ANGULAR: MACH	±1°			SIZE DWG. NO. REV		
ANGULAR: BEND	±5°			A am-3210R 2		
ONE PLACE DECIMAL	±0.1			SCALE: 1:2 WEIGHT: SHEET 1 OF 1		
TWO PLACE DECIMAL	±0.01					
THREE PLACE DECIMAL	±0.005					
FOUR PLACE DECIMAL	±0.0005					
MATERIAL	5052 AL	CHECKED	NAME	DATE		
FINISH	DEBURRED	ENG APPR.	KK	3/24/2020		
DO NOT SCALE DRAWING		MFG APPR.				
		Q.A.				