

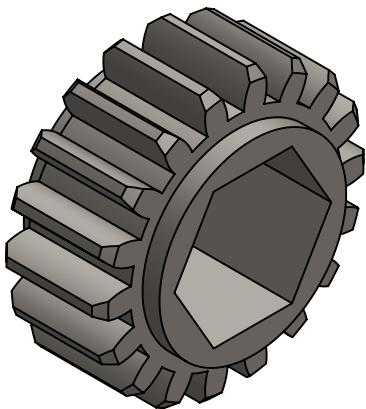

REVISION HISTORY			
REV.	DESCRIPTION	DATE	DRAWN BY
1	ORIGINAL PRINT	12/2/2019	N. MASSOUDA

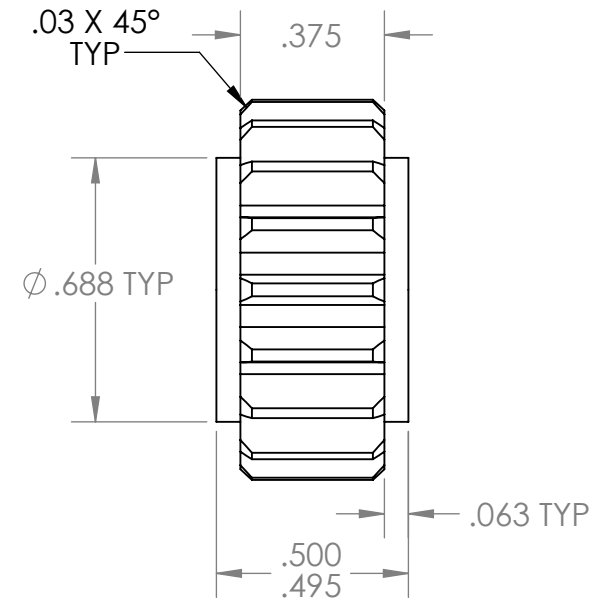
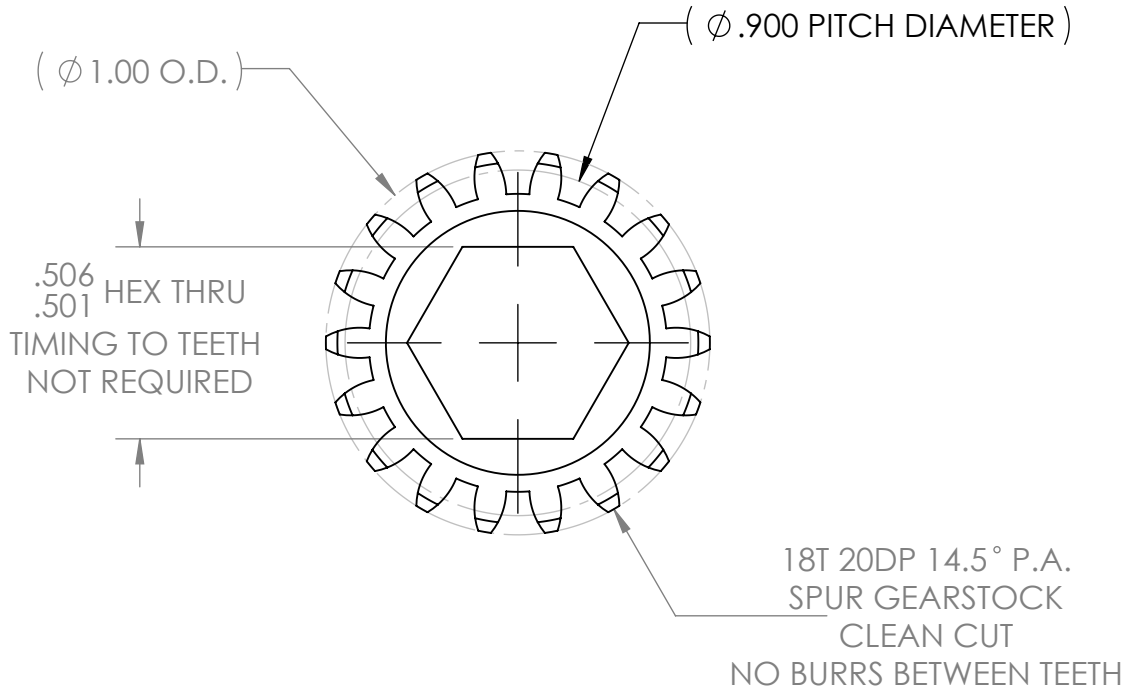

*** SEE CAD FOR ADDITIONAL TOOLPATH INFO***

UNLESS OTHERWISE SPECIFIED:		COMMENTS:				
DIMENSIONS ARE IN INCHES		DUAL DIMENSIONS ARE IN MILLIMETERS.				
TOLERANCES:		BREAK ALL SHARP EDGES		TITLE:		
FRACTIONAL	$\pm 1/16$			18T 20DP 14.5PA		
ANGULAR: MACH	$\pm 1^\circ$			0.500IN HEX BORE GEAR		
ANGULAR: BEND	$\pm 5^\circ$			SIZE	DWG. NO.	REV
ONE PLACE DECIMAL	± 0.1			A	am-4212	1
TWO PLACE DECIMAL	± 0.01			SCALE: 2:1 WEIGHT: SHEET 1 OF 1		
THREE PLACE DECIMAL	± 0.005					
FOUR PLACE DECIMAL	± 0.0005					
MATERIAL						
4140 STEEL		NAME	DATE			
		CHECKED	NL	12/2/19		
FINISH		ENG APPR.				
DEBURR & ZINC PLATE		MFG APPR.				
DO NOT SCALE DRAWING		Q.A.				