

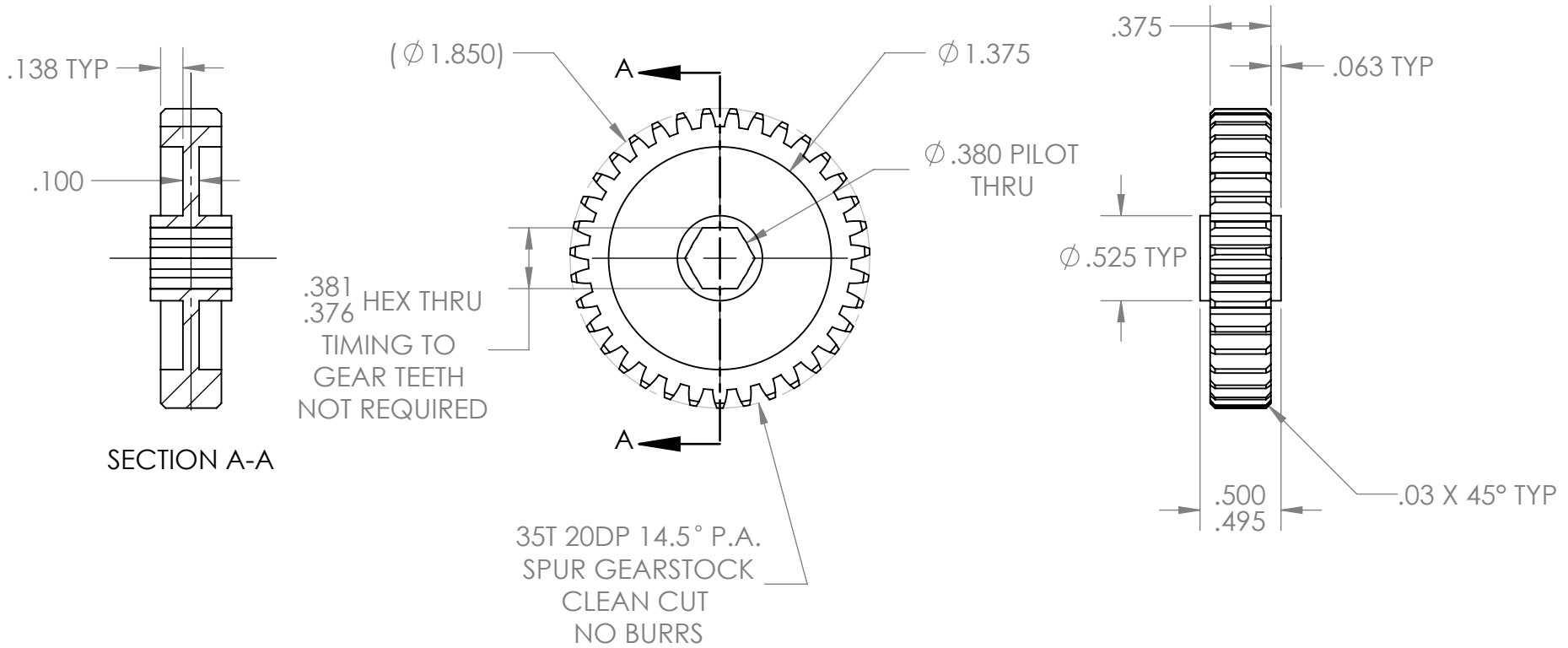

REVISION HISTORY			
REV.	DESCRIPTION	DATE	DRAWN BY
1	ORIGINAL PRINT	6/19/2017	K. STAHLCKER

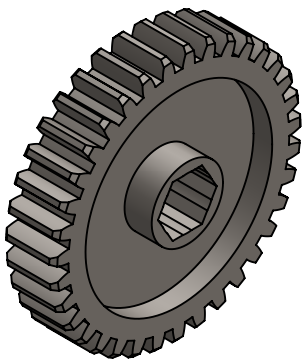

\*\*\* SEE CAD FOR ADDITIONAL TOOLPATH INFO\*\*\*



UNLESS OTHERWISE SPECIFIED:		COMMENTS:				
<b>DIMENSIONS ARE IN INCHES</b>		DUAL DIMENSIONS ARE IN MILLIMETERS.				
TOLERANCES:		BREAK ALL SHARP EDGES		TITLE:		
FRACTIONAL	$\pm 1/16$			35T 20DP 14.5PA 0.375IN		
ANGULAR: MACH	$\pm 1^\circ$			HEX BORE GEAR		
ANGULAR: BEND	$\pm 5^\circ$			SIZE	DWG. NO.	REV
ONE PLACE DECIMAL	$\pm 0.1$			<b>A</b>	am-4186	1
TWO PLACE DECIMAL	$\pm 0.01$			SCALE: 1:1 WEIGHT: SHEET 1 OF 1		
THREE PLACE DECIMAL	$\pm 0.005$					
FOUR PLACE DECIMAL	$\pm 0.0005$					
MATERIAL	4140 STEEL	CHECKED	NAME	DATE		
FINISH	DEBURR & ZINC PLATE	ENG APPR.	NL	10/21/19		
DO NOT SCALE DRAWING		MFG APPR.				
		Q.A.				