

REVISION HISTORY			
REV.	DESCRIPTION	DATE	DRAWN BY
1	ORIGINAL PRINT	4/1/2020	N. LAWRENCE
2	REMOVED HUB FROM GEAR, MADE 0.5IN TOTAL WIDTH	4/2/2020	N. LAWRENCE
3	CHANGED GEAR MATERIAL, ADDED HARDNESS SPEC, CHANGED PART NUMBER	4/14/2020	N. LAWRENCE
4	UPDATED GEAR MATL AGAIN, REMOVED HARDNESS SPEC, RESTORED PART NUMBER	7/7/2020	N. LAWRENCE

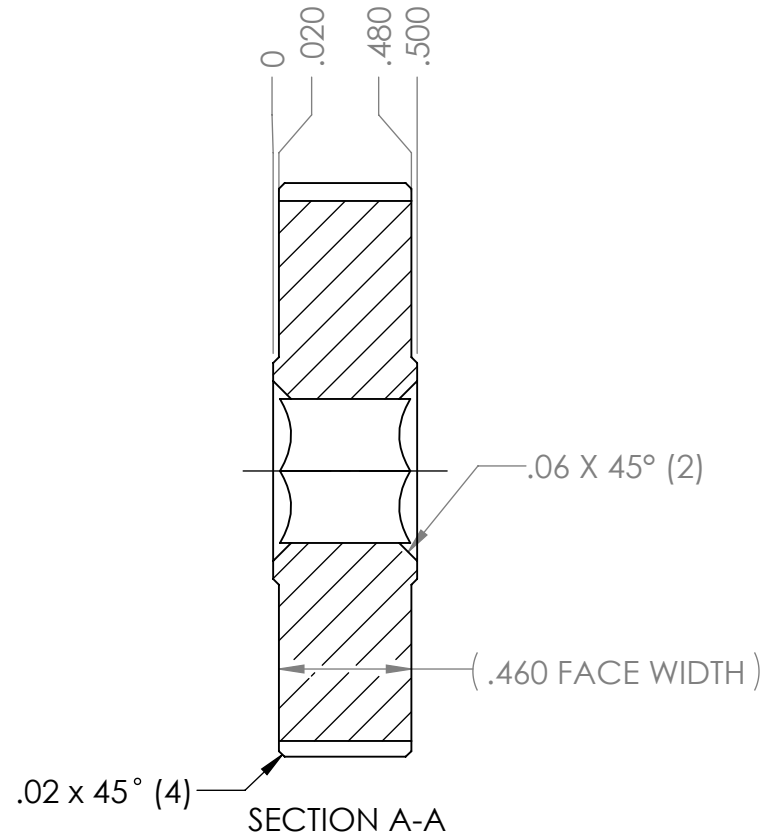

\*\*\* SEE CAD FOR ADDITIONAL TOOLPATH INFO\*\*\*

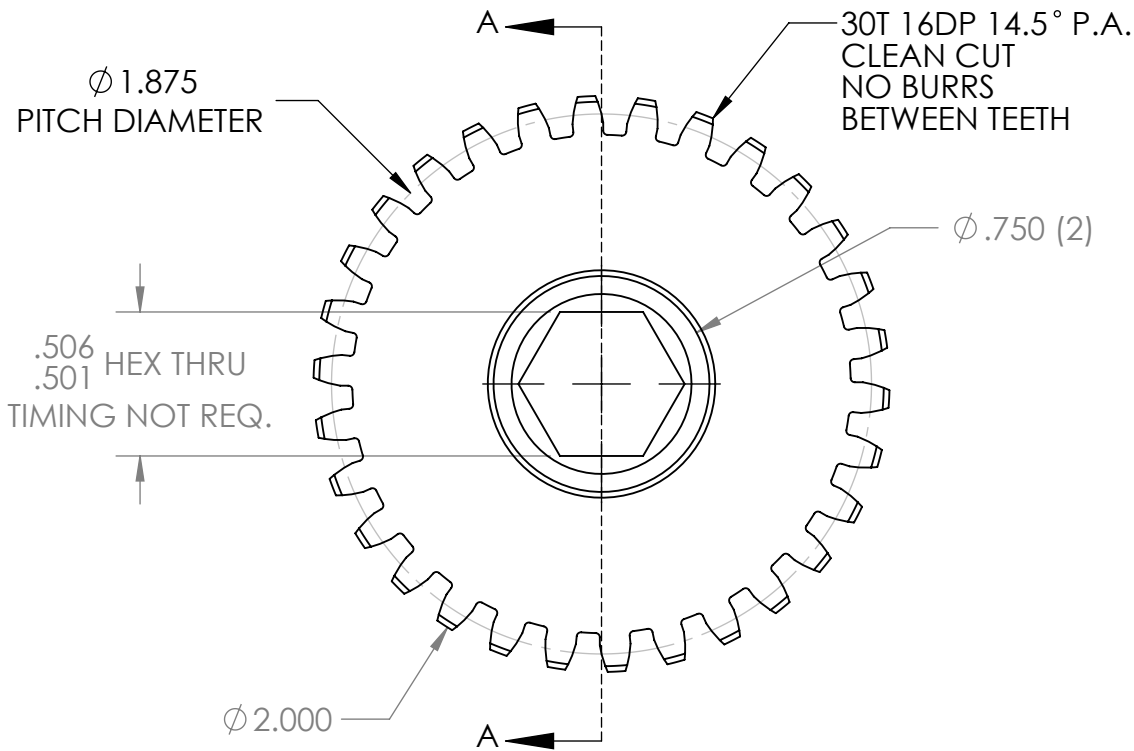
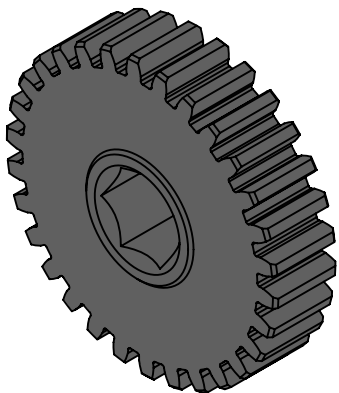

UNLESS OTHERWISE SPECIFIED:		COMMENTS:	
<b>DIMENSIONS ARE IN INCHES</b>		DUAL DIMENSIONS ARE IN MILLIMETERS.	
TOLERANCES:		BREAK ALL SHARP EDGES.	
FRACTIONAL	±1/16		
ANGULAR: MACH	±1°		
ANGULAR: BEND	±5°		
ONE PLACE DECIMAL	±0.1		
TWO PLACE DECIMAL	±0.01		
THREE PLACE DECIMAL	±0.005		
FOUR PLACE DECIMAL	±0.0005		
MATERIAL	1117, 1045 OR 4140 STEEL	CHECKED	NAME KK
FINISH	DEBURRED ZINC PLATE	ENG APPR.	DATE 4/2/20
DO NOT SCALE DRAWING		MFG APPR.	
		Q.A.	



TITLE:  
**30T 16DP 14.5PA  
 500HEX BORE GEAR**

SIZE	DWG. NO.	REV
<b>A</b>	<b>am-4254</b>	<b>4</b>
SCALE: 1.5:1		SHEET 1 OF 1