

REVISION HISTORY			
REV.	DESCRIPTION	DATE	DRAWN BY
1	ORIGINAL PRINT, REDESIGN OF am-3016c	8/25/2020	N. MASSOUDA

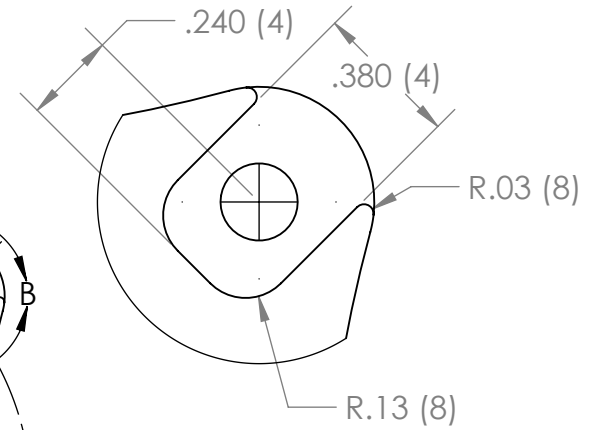

DETAIL B
SCALE 2:1

*** SEE CAD FOR ADDITIONAL TOOLPATH INFO***

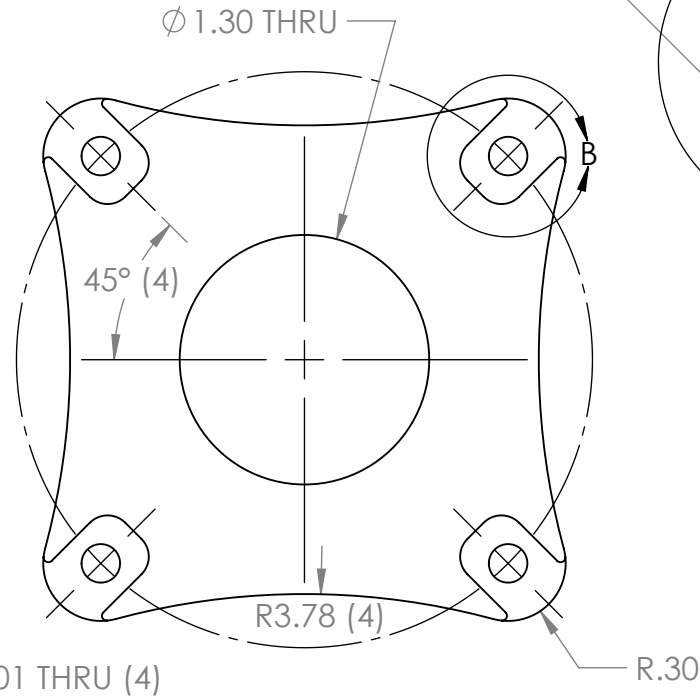
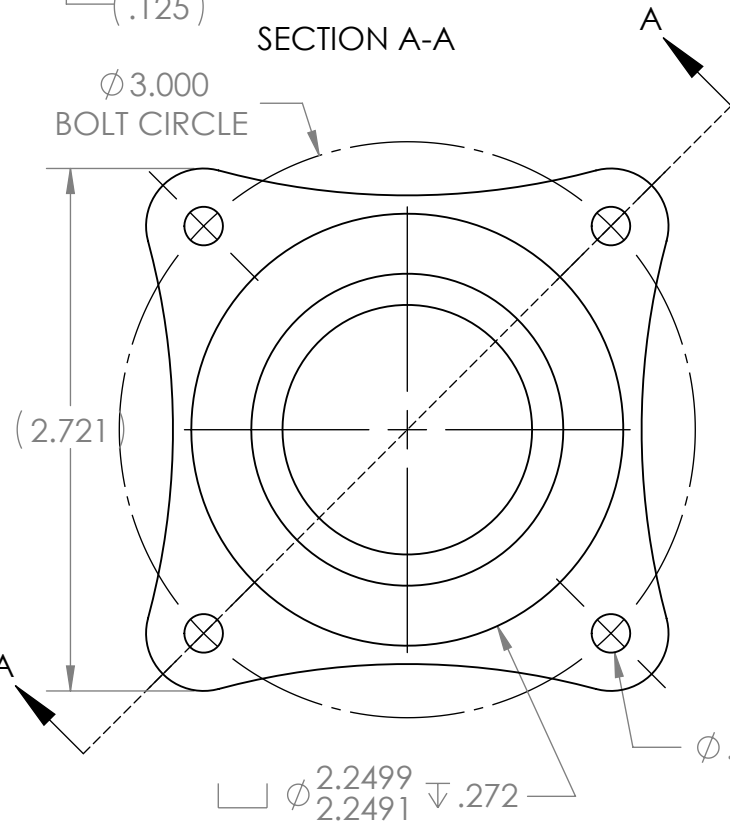
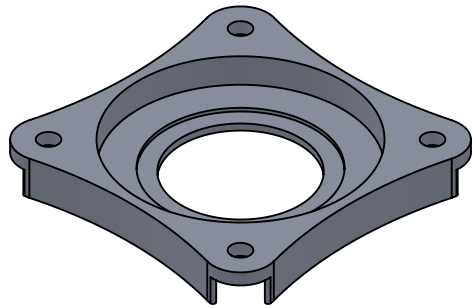

UNLESS OTHERWISE SPECIFIED:		COMMENTS:	
DIMENSIONS ARE IN INCHES		DUAL DIMENSIONS ARE IN MILLIMETERS.	
TOLERANCES:		BREAK ALL SHARP EDGES	
FRACTIONAL	±1/16		
ANGULAR: MACH	±1°		
ANGULAR: BEND	±5°		
ONE PLACE DECIMAL	±0.1		
TWO PLACE DECIMAL	±0.01		
THREE PLACE DECIMAL	±0.005		
FOUR PLACE DECIMAL	±0.0005		
MATERIAL	6061-T6 ALUMINUM	NAME	DATE
FINISH	TUMBLER	CHECKED	NL 8/25/20
		ENG APPR.	
		MFG APPR.	
	DO NOT SCALE DRAWING	Q.A.	



TITLE:
**SWERVE & STEER
BEARING PLATE**

SIZE	DWG. NO.	REV
A	am-3016c	1
SCALE: 1:1	WEIGHT:	SHEET 1 OF 1