

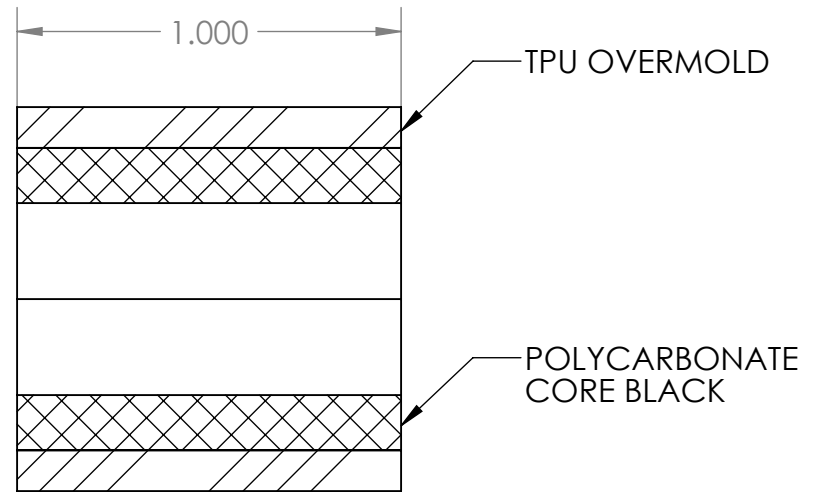

REVISION HISTORY			
REV.	DESCRIPTION	DATE	DRAWN BY
1	ORIGINAL PRINT	3/9/2021	N. LAWRENCE

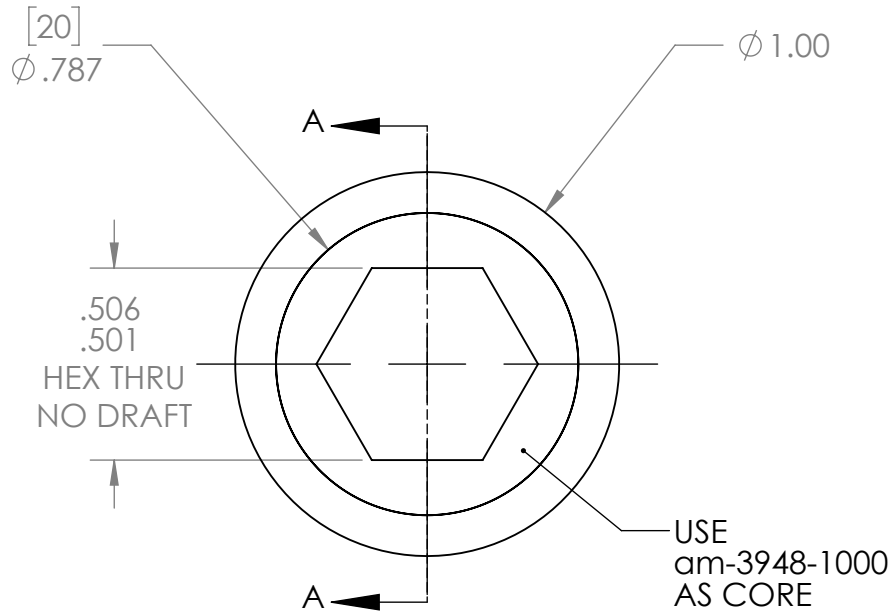
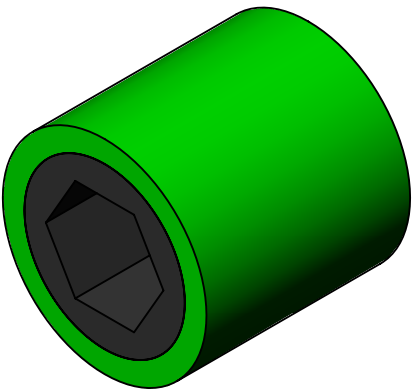

SECTION A-A

*** SEE CAD FOR ADDITIONAL TOOLPATH INFO***



UNLESS OTHERWISE SPECIFIED:		COMMENTS:				
DIMENSIONS ARE IN INCHES		DUAL DIMENSIONS ARE IN MILLIMETERS.				
TOLERANCES:		BREAK ALL SHARP EDGES.		TITLE:		
FRACTIONAL	±1/16			SUSHI ROLLER		
ANGULAR: MACH	±1°			500 HEX BORE		
ANGULAR: BEND	±5°			SIZE	DWG. NO.	REV
ONE PLACE DECIMAL	±0.1			A	am-4541	1
TWO PLACE DECIMAL	±0.01			SCALE: 2:1		
THREE PLACE DECIMAL	±0.005			SHEET 1 OF 1		
FOUR PLACE DECIMAL	±0.0005					
MATERIAL	PC CORE TPU OVERMOLD	CHECKED	NAME	DATE		
FINISH	DEBURRED	ENG APPR.	NM	3/9/21		
DO NOT SCALE DRAWING		MFG APPR.				
		Q.A.				