

User Guide

1:1 LJ Bevel Box

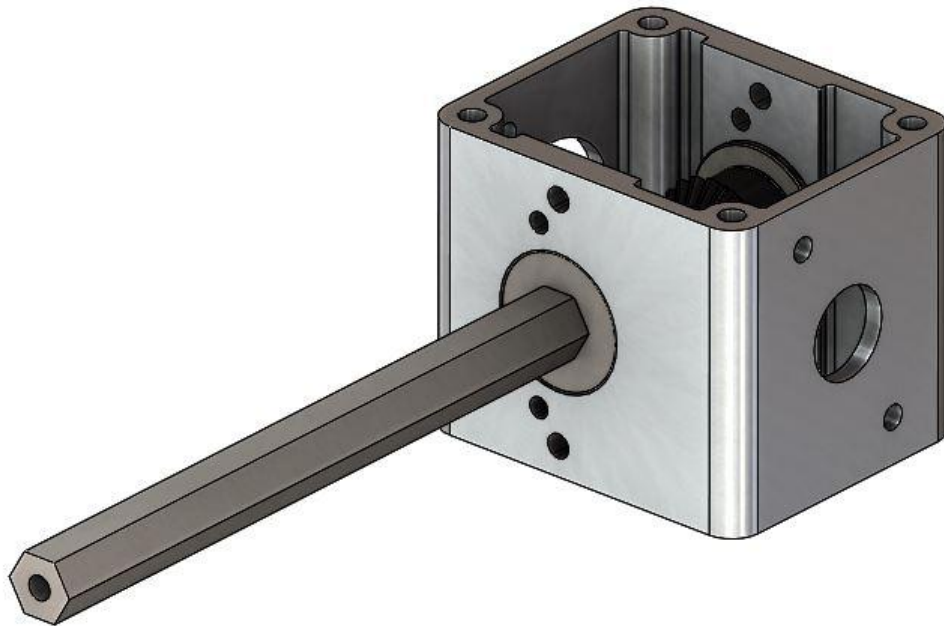

1.1 LJ Bevel Box, 57 Sport (am-3840 SPORT)

Step 1: Refer to the 57 Sport Motor Installation Guide to attach the Redline motor to the 57

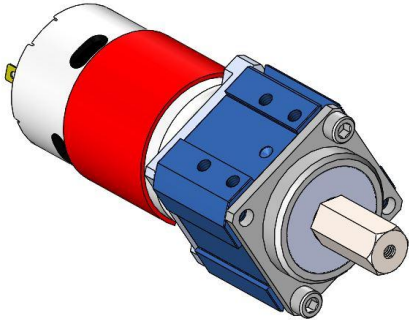

Step 2: Slide the Sport Face Mount Spacer (am-3787) onto the face of the 57 Sport

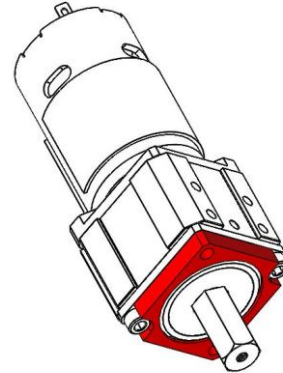

Step 3: Slide the 57 LJ Bevel Box Spacer (am-3834) onto the output shaft of the 57 Sport.

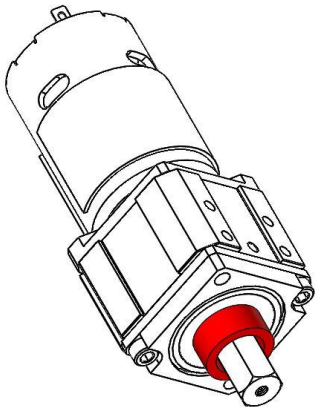

Step 4: Then slide the 20T 0.5in Hex Bore Miter Gear (am-3772) onto the hex shaft.

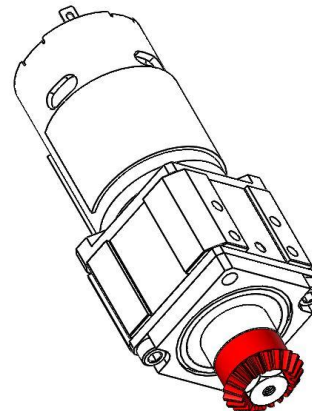

Step 5: Press the FR8ZZ-HexHD bearing (am-2986) into the LJ Bevel Box housing (am-2689a).

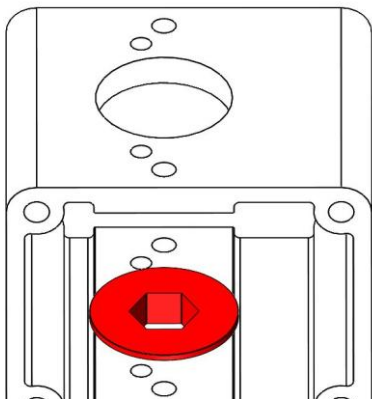

Step 6: Flip the bevel box housing and press in the FR6ZZ-L bearing (am-0573).

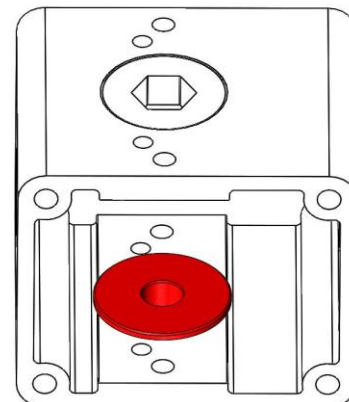

Step 7: Slide the Long Hex Output Shaft (am-3523) into the bevel box housing.

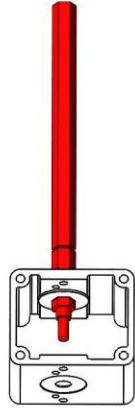

Step 8: Place shim washer (am-1444), 20T 0.5in Hex Bore Miter Gear (am-3772), then Output Shaft Spacer (am-1445) onto the output shaft.

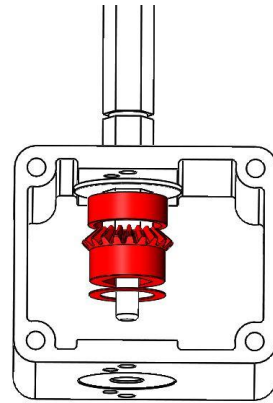

Step 9: Arrange the shim, miter gear and spacer.

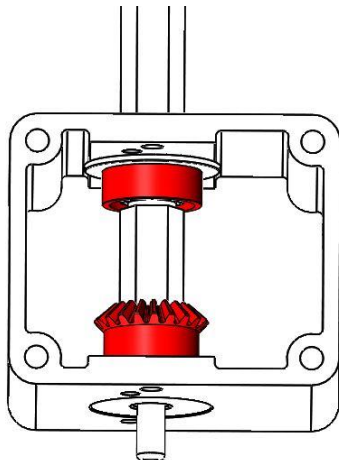

Step 10: Place e-clip (am-0206) on the hex shaft.

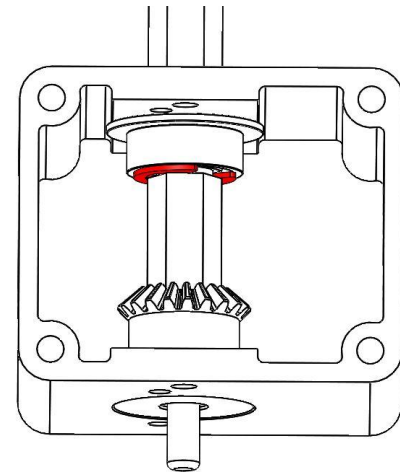

Step 11: Line up assembly from Step 4 and insert into LJ housing.

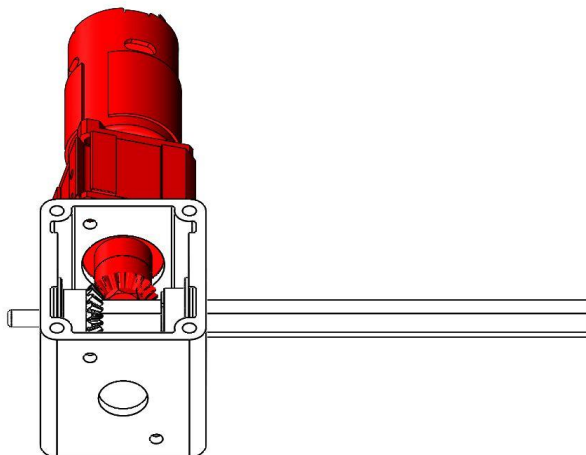

Step 12: Mount the assembly into the LJ housing with two 10-32 x 0.75 SHCS.

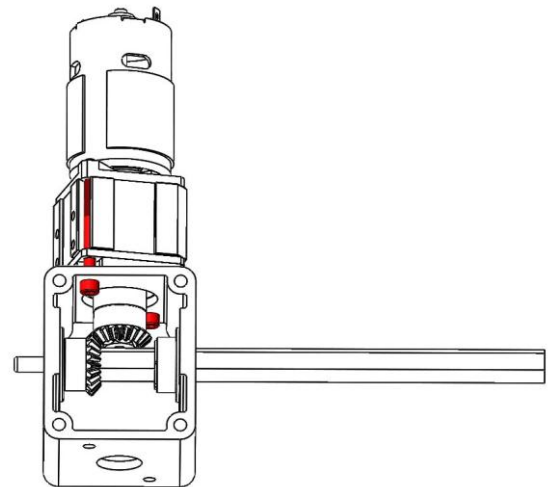

1.1 LJ Bevel Box, CIM (am-3840 CIM)

Step 1: Press the FR8ZZ-HexHD bearing (am-2986) into the LJ Bevel Box housing (am-2689a).

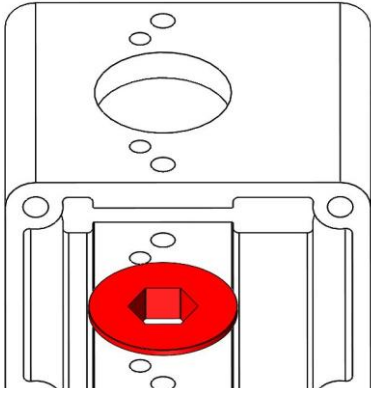

Step 2: Flip the bevel box housing and press in the FR6ZZ-L bearing (am-0573).

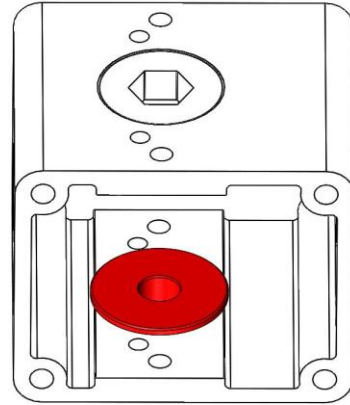

Step 3: Slide CIM motor into the bevel box

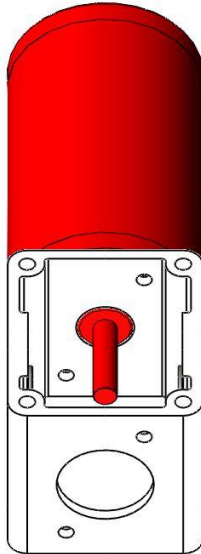

Step 4: Mount with two 10-32 x 5/8" SHCS.

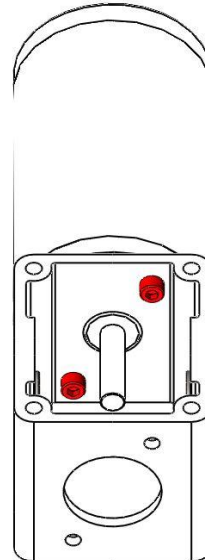

Step 5: Slide on brass washer (am-1322).

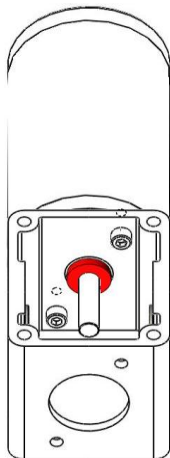

Step 6: Press key into CIM Shaft.

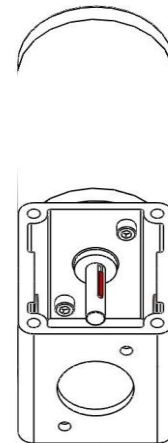

Step 7: Slide CIM Motor LJ Bevel Box Spacer (am-3803) and 20T 2 mm Keyway Bore Miter Gear (am-3776)

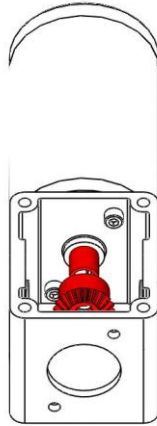

Step 8: Press retaining ring (am-0033) onto the shaft of the CIM.

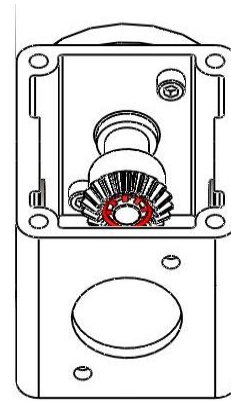

Step 9: Slide the Long Hex Output Shaft (am-3523) into the bevel box housing.

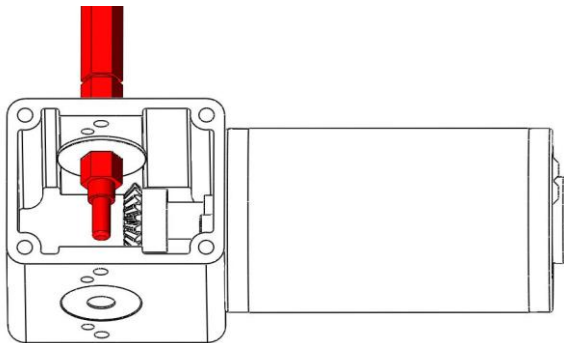

Step 10: Place Output Shaft Spacer (am-1445) onto the output shaft.

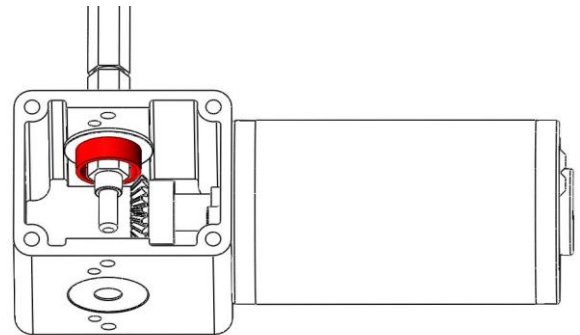

Step 11: Place the 20T 0.5in Hex Bore Miter Gear (am-3772), then shim washer (am-1444),

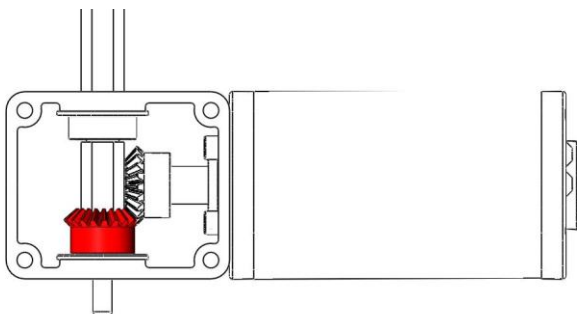

Step 12: Place e-clip (am-0206) on the hex shaft.

