

REVISION HISTORY			
REV.	DESCRIPTION	DATE	DRAWN BY
1	ORIGINAL PRINT	1/21/2021	N. MASSOUDA
2	PIPE INTERFACE, BOLT CIRCLE	3/8/2021	N. MASSOUDA
3	ADDED ADITONAL BOLT CIRCLE	3/10/2021	N. MASSOUDA
4	FINALIZED BOLT CIRCLE, ADDED RECYCLE LOGOS	4/16/2021	N. MASSOUDA

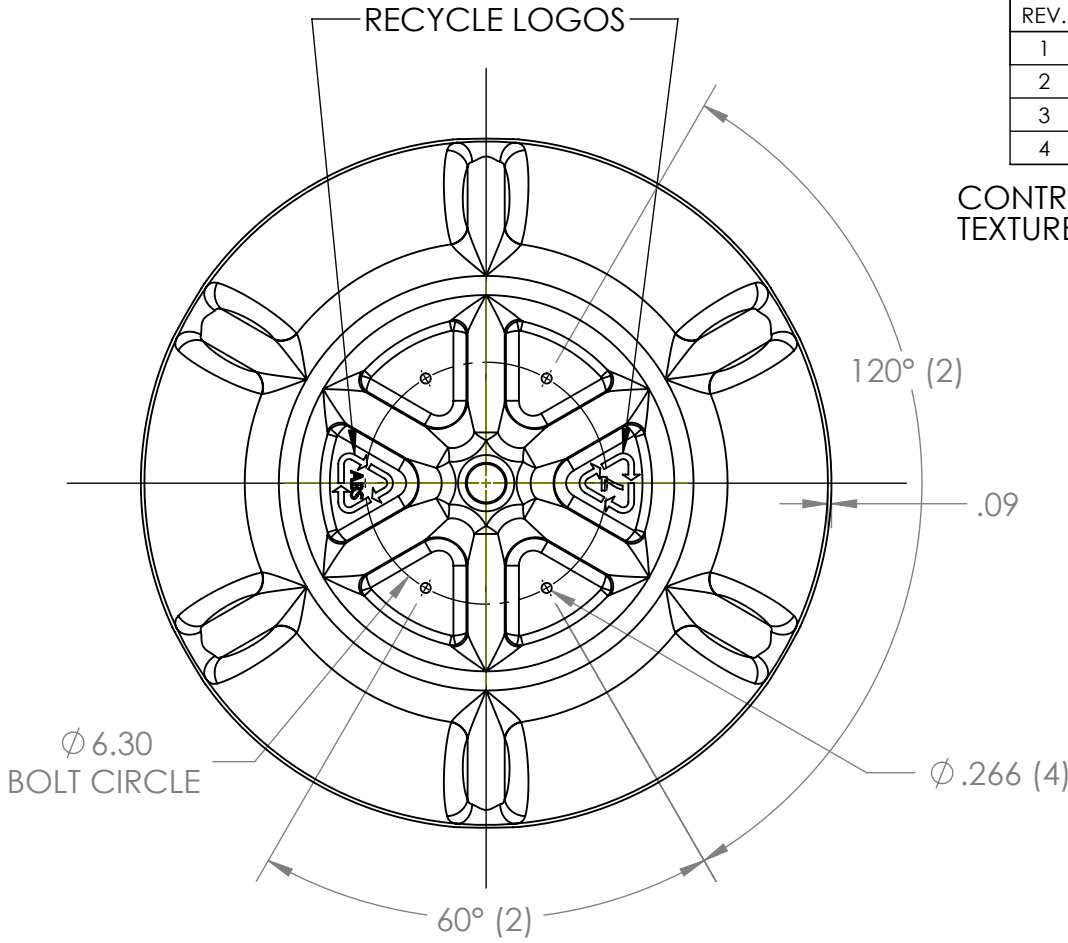

CONTROLLED (MOLD) AND TEXTURED SURFACE

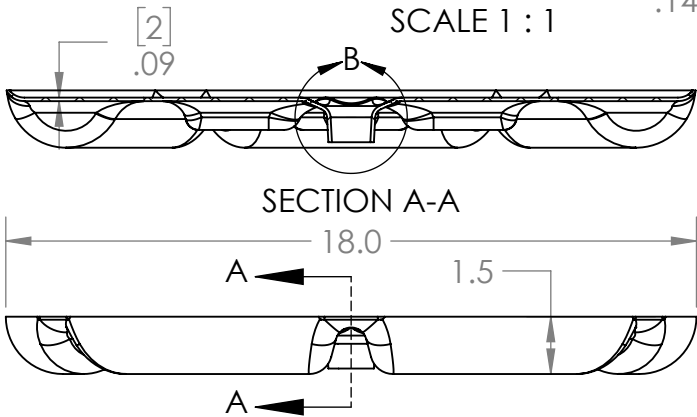
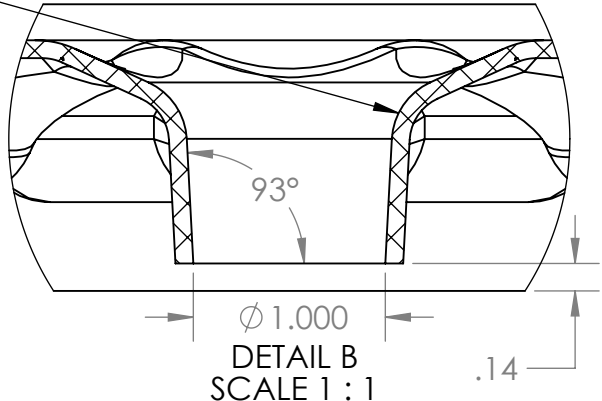

*** SEE CAD FOR ADDITIONAL TOOLPATH INFO***

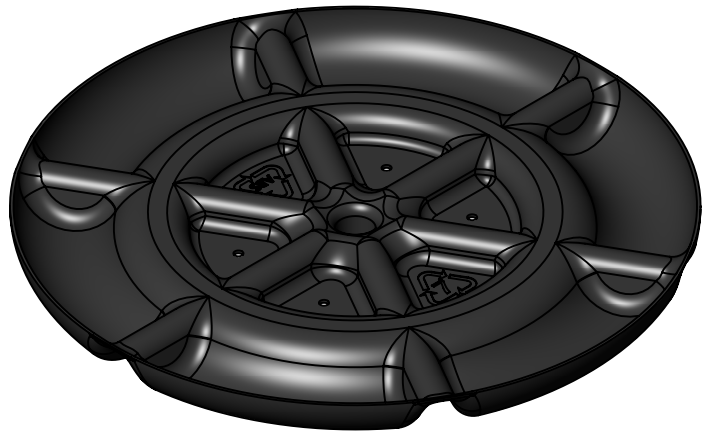

UNLESS OTHERWISE SPECIFIED:		COMMENTS:	
DIMENSIONS ARE IN INCHES		DUAL DIMENSIONS ARE IN MILLIMETERS.	
TOLERANCES:		BREAK ALL SHARP EDGES	
FRACTIONAL	±1/16		
ANGULAR: MACH	±1°		
ANGULAR: BEND	±5°		
ONE PLACE DECIMAL	±0.1		
TWO PLACE DECIMAL	±0.01		
THREE PLACE DECIMAL	±0.005		
FOUR PLACE DECIMAL	±0.0005		
MATERIAL	0.093" BLACK ABS	NAME	DATE
FINISH	DEBURRED	CHECKED	KK 4/16/21
		ENG APPR.	
		MFG APPR.	
	DO NOT SCALE DRAWING	Q.A.	



TITLE:			
SHIPPING HUB LOWER TRAY			
SIZE	DWG. NO.	REV	
A	am-4491	4	
SCALE: 1:5	WEIGHT:	SHEET 1 OF 1	