

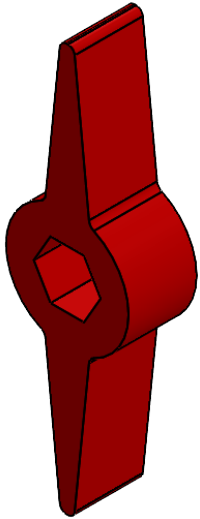

REVISION HISTORY			
REV.	DESCRIPTION	DATE	DRAWN BY
1	ORIGINAL PRINT	9/1/2021	N. MASSOUDA

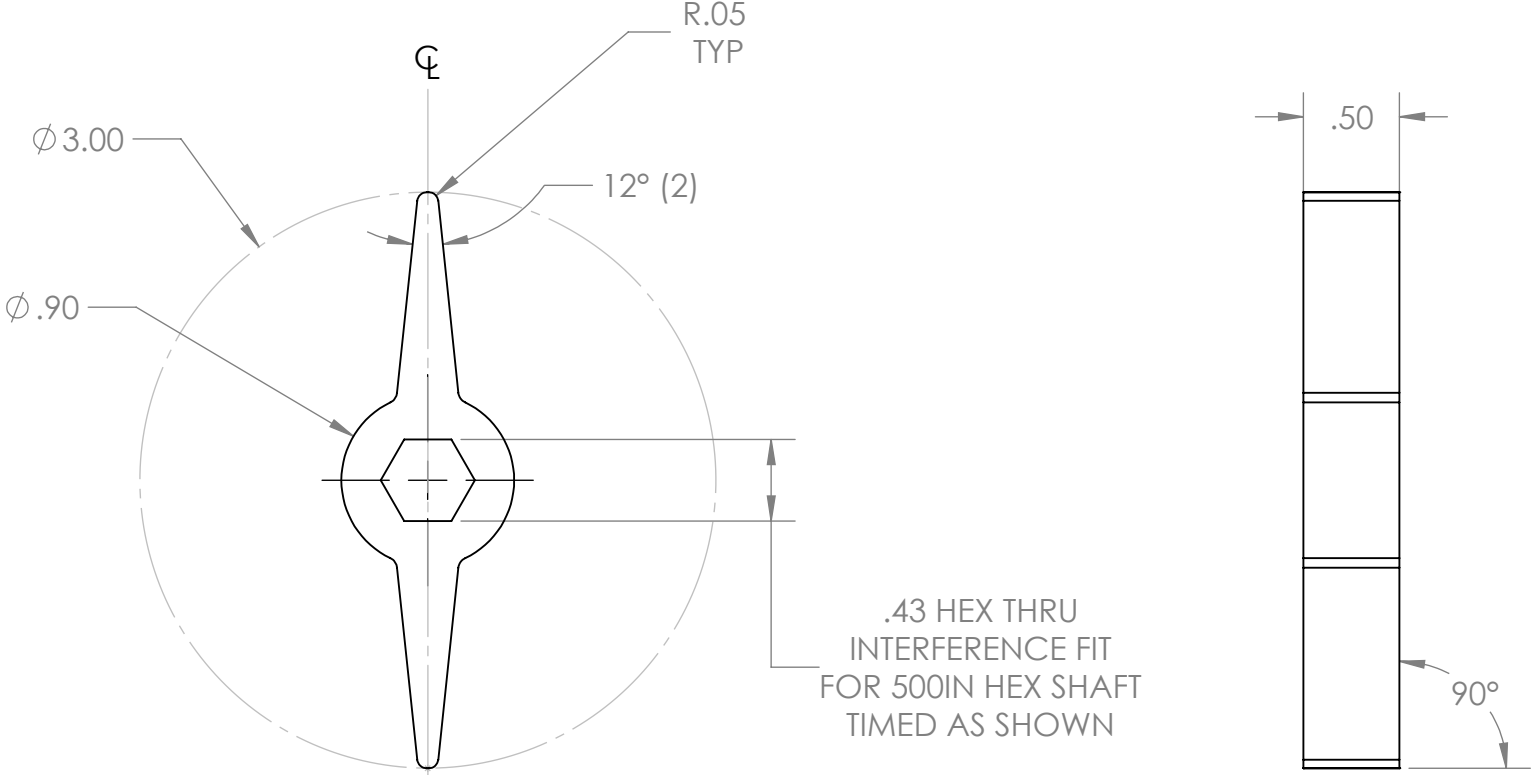

*** SEE CAD FOR ADDITIONAL TOOLPATH INFO***

UNLESS OTHERWISE SPECIFIED:		COMMENTS:					
DIMENSIONS ARE IN INCHES		DUAL DIMENSIONS ARE IN MILLIMETERS.					
TOLERANCES: FRACTIONAL $\pm 1/16$ ANGULAR: MACH $\pm 1^\circ$ ANGULAR: BEND $\pm 5^\circ$ ONE PLACE DECIMAL ± 0.1 TWO PLACE DECIMAL ± 0.01 THREE PLACE DECIMAL ± 0.005 FOUR PLACE DECIMAL ± 0.0005		BREAK ALL SHARP EDGES		TITLE: 3IN 500IN HEX BORE SPINTAKE			
MATERIAL 45A RED SILICONE		CHECKED	NAME NL	DATE 9/1/21	SIZE A	DWG. NO. am-4622	REV 1
FINISH DEBURRED		ENG APPR.		MFG APPR.		SCALE: 1:1 WEIGHT: SHEET 1 OF 1	
DO NOT SCALE DRAWING		Q.A.					