

4

3

2

1

REVISION HISTORY			
REV.	DESCRIPTION	DATE	DRAWN BY
1	ORIGINAL PRINT	11/17/2021	N. LAWRENCE
2	ADJUSTED 2" BOLT CIRCLE POSITION	12/3/2021	N. LAWRENCE

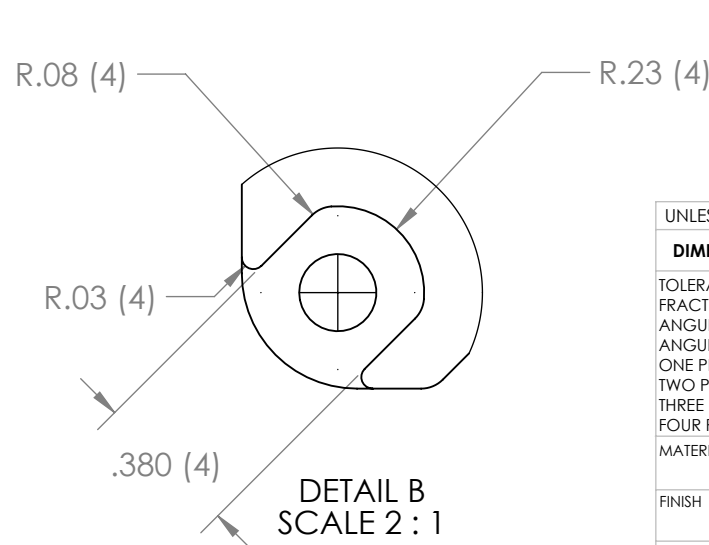
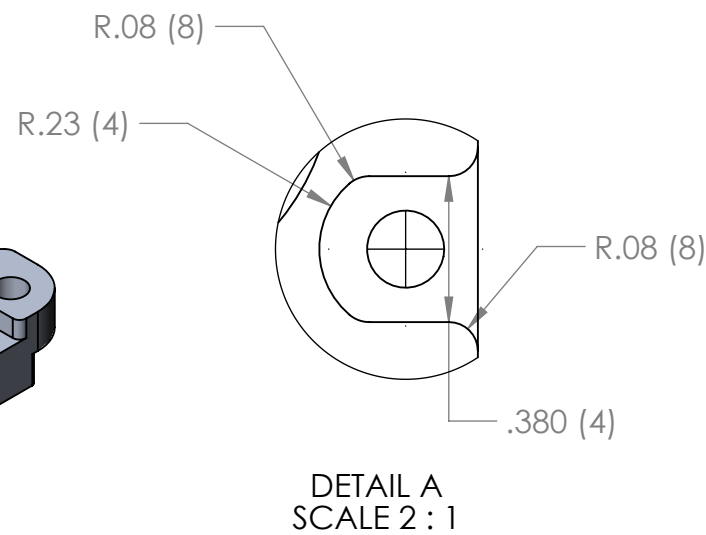
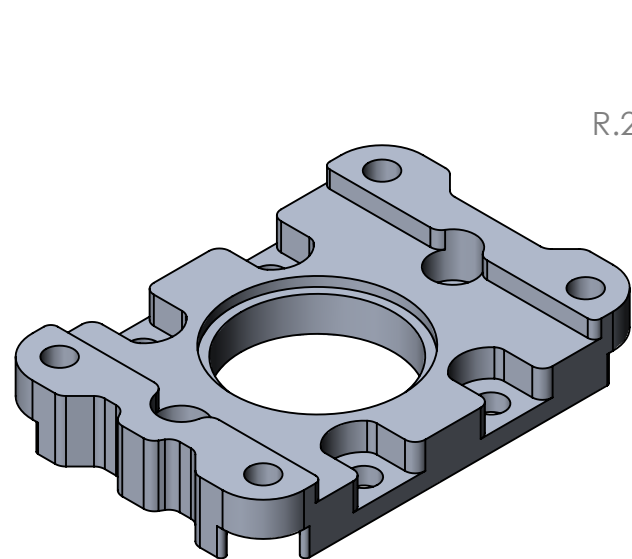
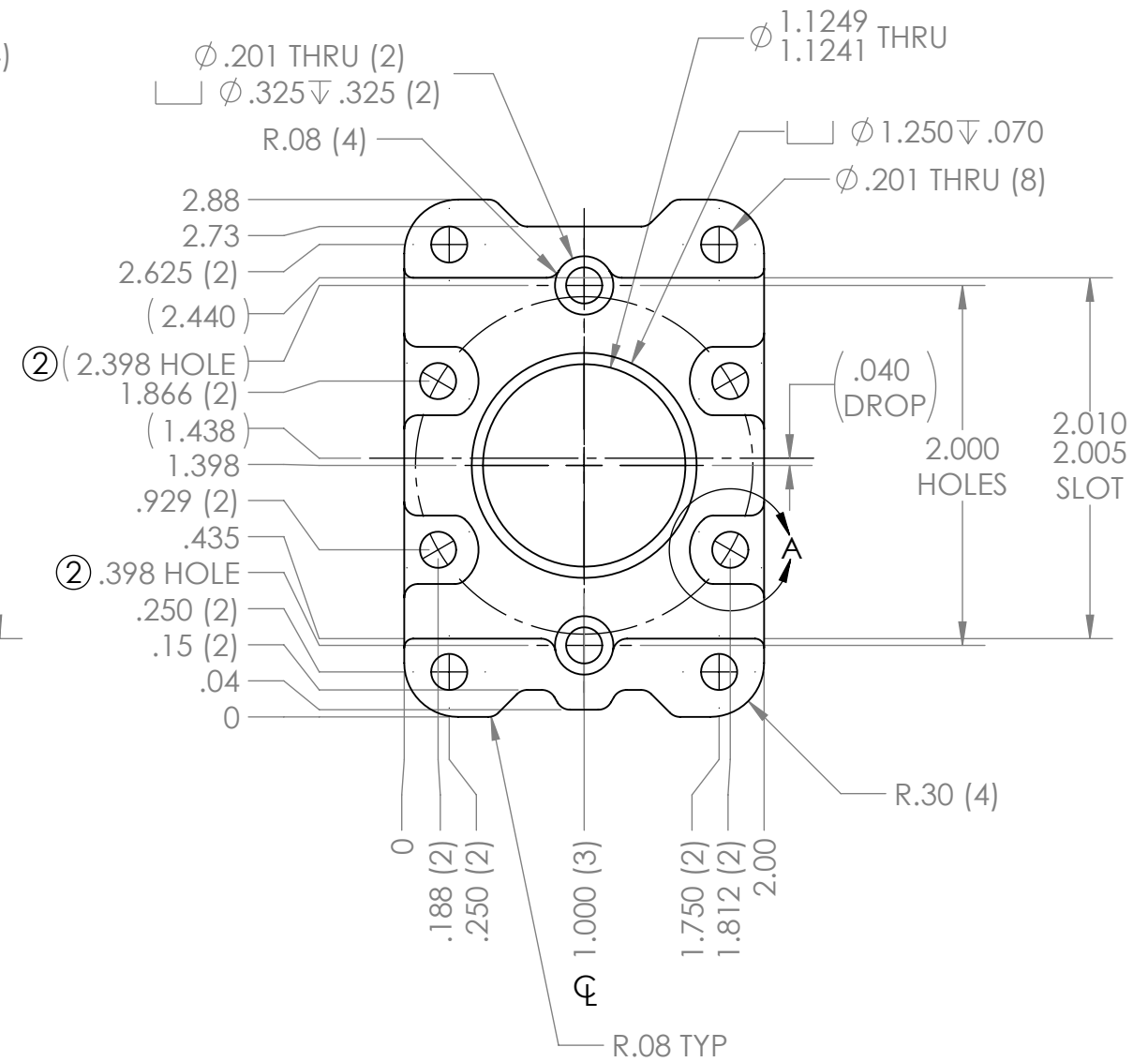
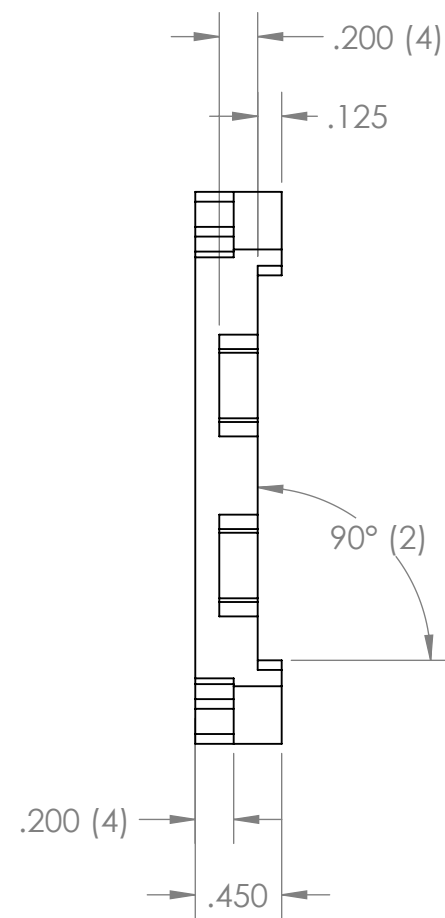
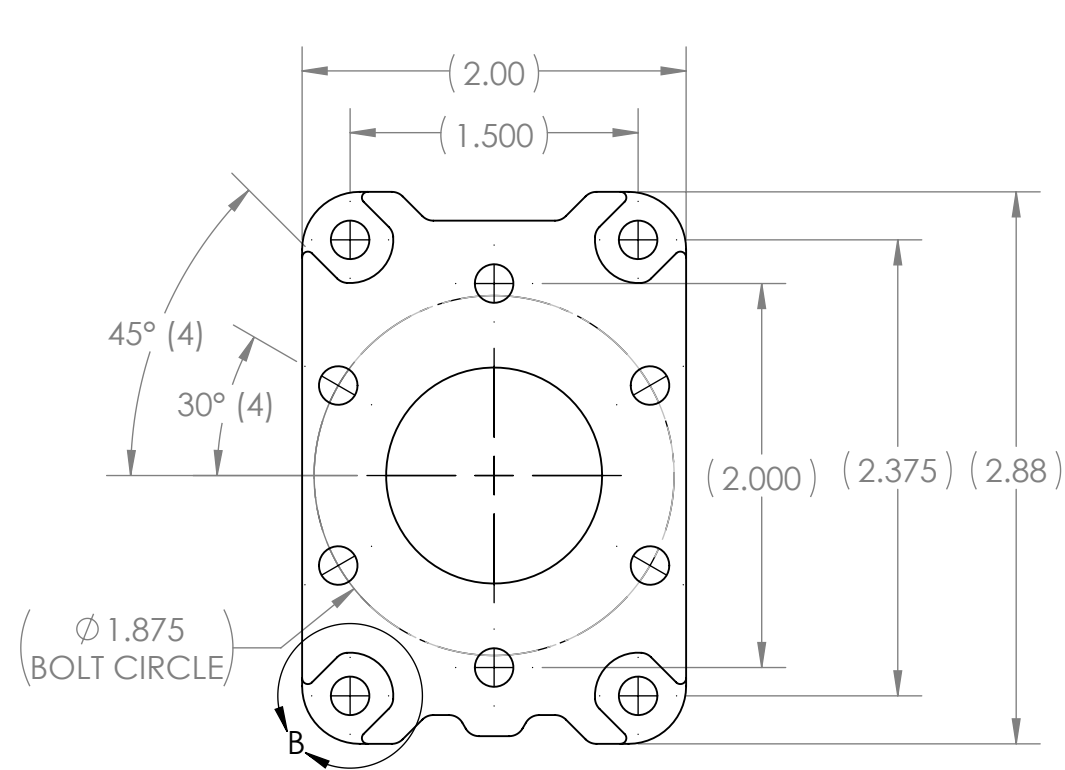

*** SEE CAD FOR ADDITIONAL TOOLPATH INFO***

UNLESS OTHERWISE SPECIFIED:		COMMENTS:	
DIMENSIONS ARE IN INCHES		DUAL DIMENSIONS ARE IN MILLIMETERS.	
TOLERANCES:		BREAK ALL SHARP EDGES.	
FRACTIONAL	±1/16		
ANGULAR: MACH	±1°		
ANGULAR: BEND	±5°		
ONE PLACE DECIMAL	±0.1		
TWO PLACE DECIMAL	±0.01		
THREE PLACE DECIMAL	±0.005		
FOUR PLACE DECIMAL	±0.0005		
MATERIAL	6061-T6 AL	NAME	DATE
FINISH	DEBURRED	CHECKED	
		ENG APPR.	
		MFG APPR.	
		Q.A.	
DO NOT SCALE DRAWING			



TITLE:
**2x1 WCD
BEARING BLOCK**

SIZE	DWG. NO.	REV
B	am-4560	2
SCALE: 1:1		SHEET 1 OF 1

4

3

2

1