

4

3

2

1

| REVISION HISTORY | | | |
|------------------|----------------|-----------|-------------|
| REV. | DESCRIPTION | DATE | DRAWN BY |
| 1 | ORIGINAL PRINT | 1/19/2022 | N. LAWRENCE |

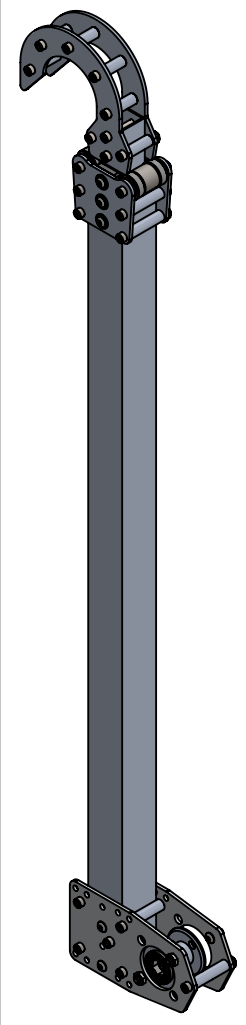
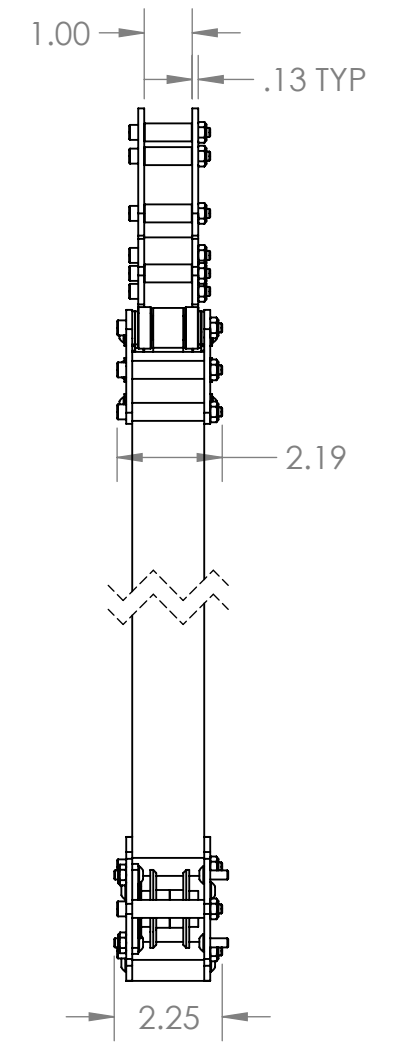
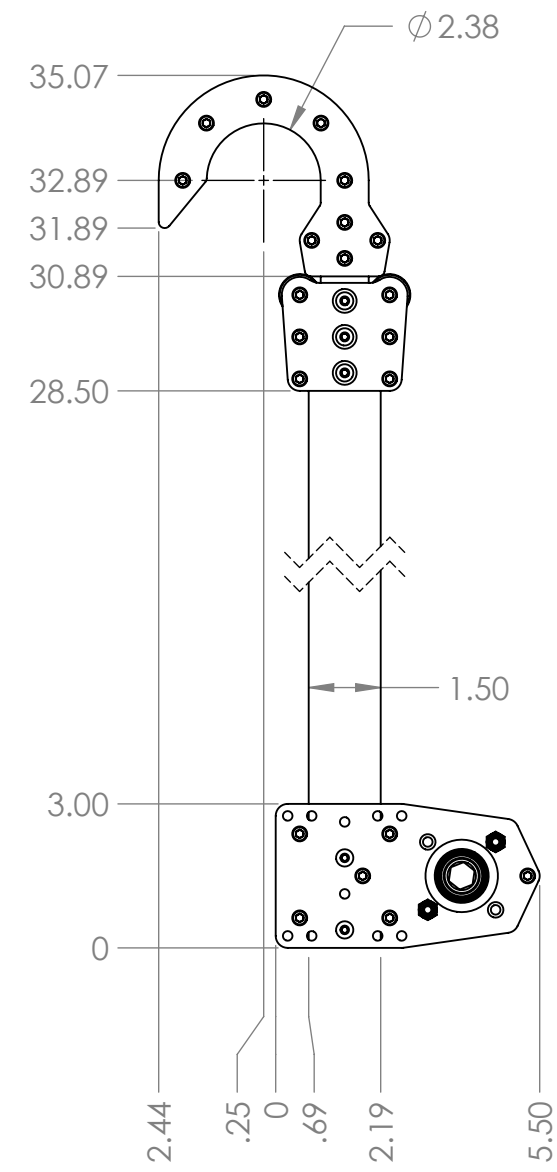
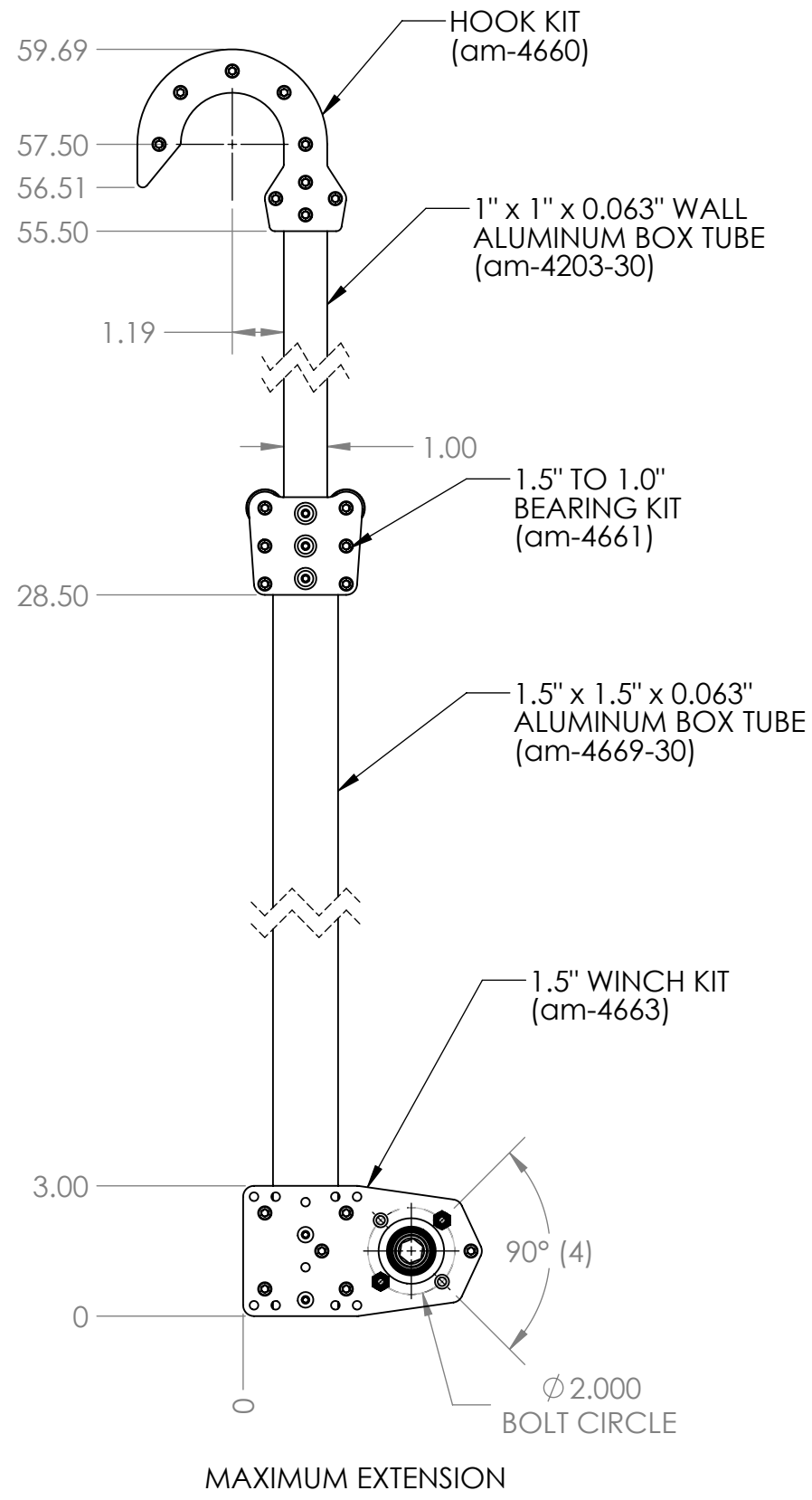

*** SEE CAD FOR ADDITIONAL TOOLPATH INFO***

| | | | | | |
|---------------------------------|---------|-------------------------------------|------|---------------------------------------------------------------------------------------|----------|
| UNLESS OTHERWISE SPECIFIED: | | COMMENTS: | |  | |
| DIMENSIONS ARE IN INCHES | | DUAL DIMENSIONS ARE IN MILLIMETERS. | | | |
| TOLERANCES: | | BREAK ALL SHARP EDGES. | | TITLE: | |
| FRACTIONAL | ±1/16 | | | 1 STAGE | |
| ANGULAR: MACH | ±1° | | | CLIMBER IN A BOX | |
| ANGULAR: BEND | ±5° | | | SIZE | DWG. NO. |
| ONE PLACE DECIMAL | ±0.1 | | | B | am-4667 |
| TWO PLACE DECIMAL | ±0.01 | | | REV | 1 |
| THREE PLACE DECIMAL | ±0.005 | | | SCALE: 1:4 SHEET 1 OF 1 | |
| FOUR PLACE DECIMAL | ±0.0005 | | | | |
| MATERIAL | VARIOUS | CHECKED | NAME | DATE | |
| FINISH | | ENG APPR. | NM | 1/19/22 | |
| DO NOT SCALE DRAWING | | MFG APPR. | | | |
| | | Q.A. | | | |

4

3

2

1

B

B

A

A