

REVISION HISTORY			
REV.	DESCRIPTION	DATE	DRAWN BY
1	ORIGINAL PRINT	9/5/2017	N. MASSOUDA
2	UPDATED TO AMDS-1	12/9/2021	B. HEININGER

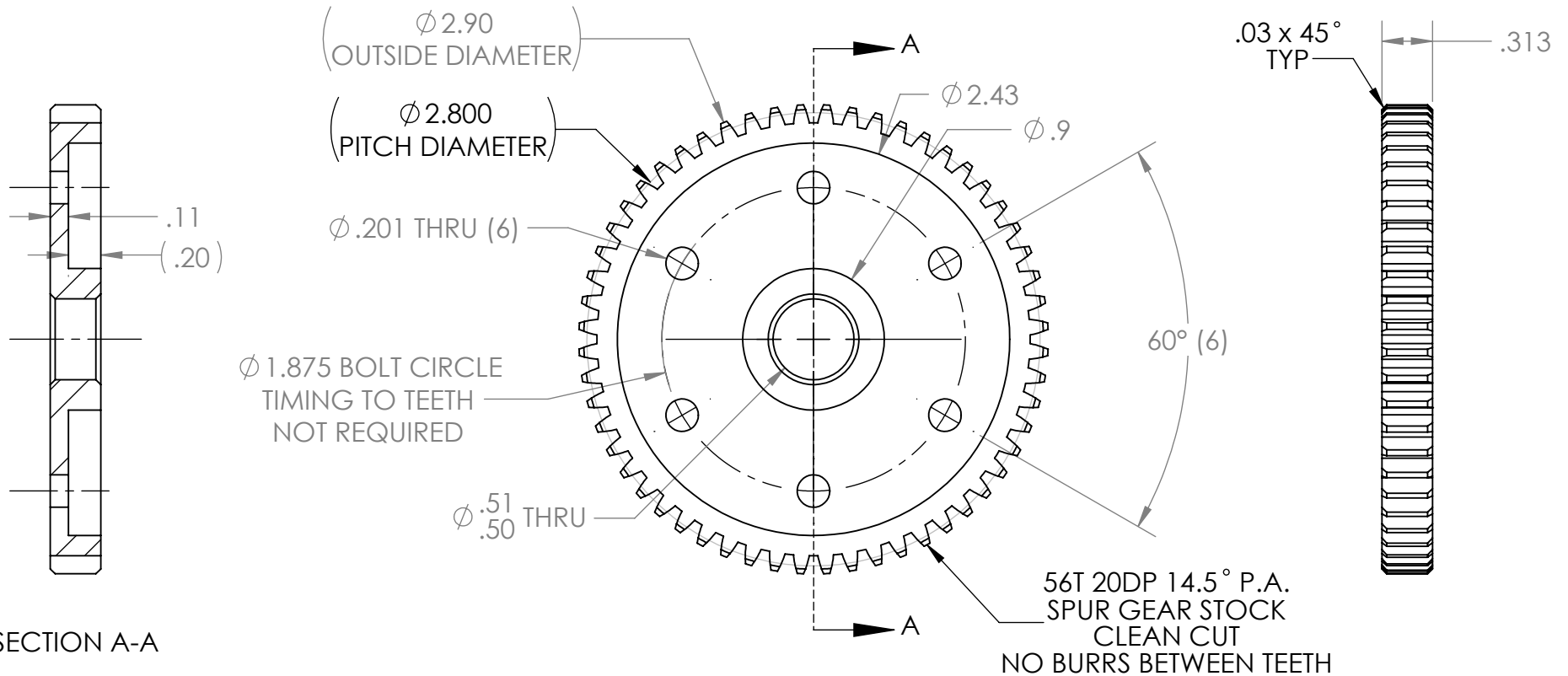

SECTION A-A

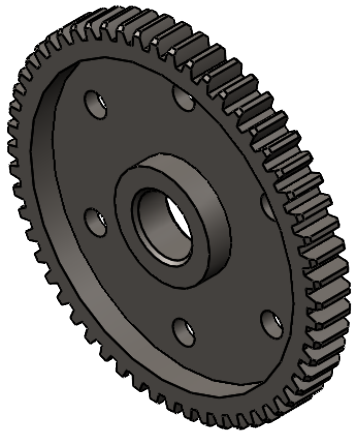

*** SEE CAD FOR ADDITIONAL TOOLPATH INFO***

UNLESS OTHERWISE SPECIFIED:		COMMENTS:				
DIMENSIONS ARE IN INCHES		DUAL DIMENSIONS ARE IN MILLIMETERS.				
TOLERANCES:		BREAK ALL SHARP EDGES.		TITLE:		
FRACTIONAL	±1/16			56T 20DP 14.5PA		
ANGULAR: MACH	±1°			500IN ROUND BORE		
ANGULAR: BEND	±5°			1.875IN BOLT CIRCLE GEAR		
ONE PLACE DECIMAL	±0.1			SIZE	DWG. NO.	REV
TWO PLACE DECIMAL	±0.01			A	am-3712	2
THREE PLACE DECIMAL	±0.005			SCALE: 1:1 SHEET 1 OF 1		
FOUR PLACE DECIMAL	±0.0005					
MATERIAL	4140 STEEL	CHECKED	NAME	DATE		
FINISH	DEBURRED ZINC PLATED	ENG APPR.	NM	2/8/22		
DO NOT SCALE DRAWING		MFG APPR.				
		Q.A.				