

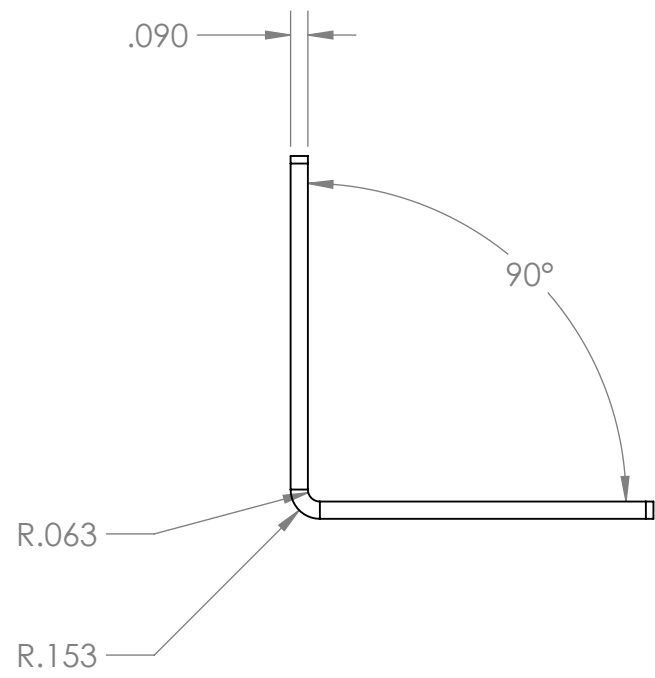

REVISION HISTORY			
REV.	DESCRIPTION	DATE	DRAWN BY
1	ORIGINAL PRINT	5/30/2017	B. HODSON
2	DRAWN TO MEET AMDS-1	5/14/2018	B. HODSON

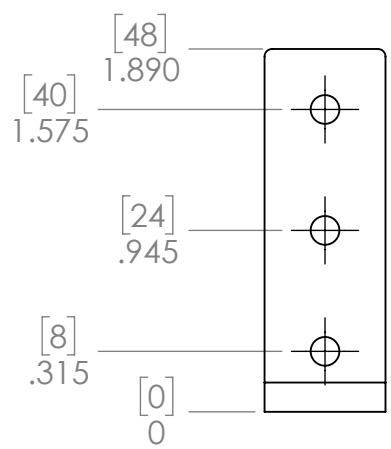

*** SEE CAD FOR ADDITIONAL TOOLPATH INFO***

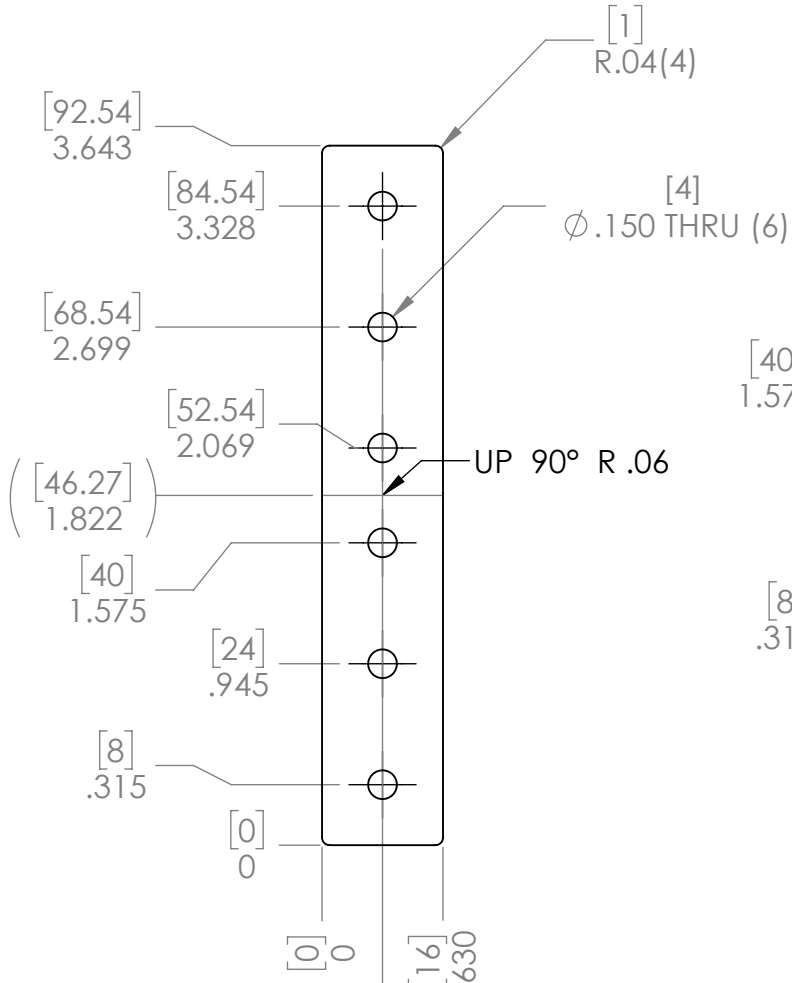
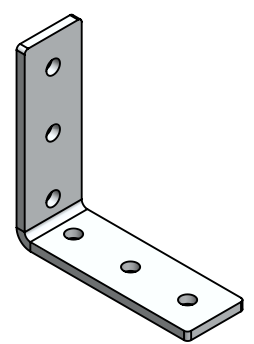

UNLESS OTHERWISE SPECIFIED:		COMMENTS:					
DIMENSIONS ARE IN INCHES		DUAL DIMENSIONS ARE IN MILLIMETERS.					
TOLERANCES: FRACTIONAL ±1/16 ANGULAR: MACH ±1° ANGULAR: BEND ±5° ONE PLACE DECIMAL ±0.1 TWO PLACE DECIMAL ±0.01 THREE PLACE DECIMAL ±0.005 FOUR PLACE DECIMAL ±0.0005		BREAK ALL SHARP EDGES.		TITLE: CORNER GUSSET (S3 TUBE)			
MATERIAL 5052 ALUMINUM		CHECKED	NAME NL	DATE 5/16/18	SIZE A	DWG. NO. am-3606	REV 2
FINISH TUMBLED		MFG APPR.		SCALE: 1:1			SHEET 1 OF 1
DO NOT SCALE DRAWING		Q.A.					