

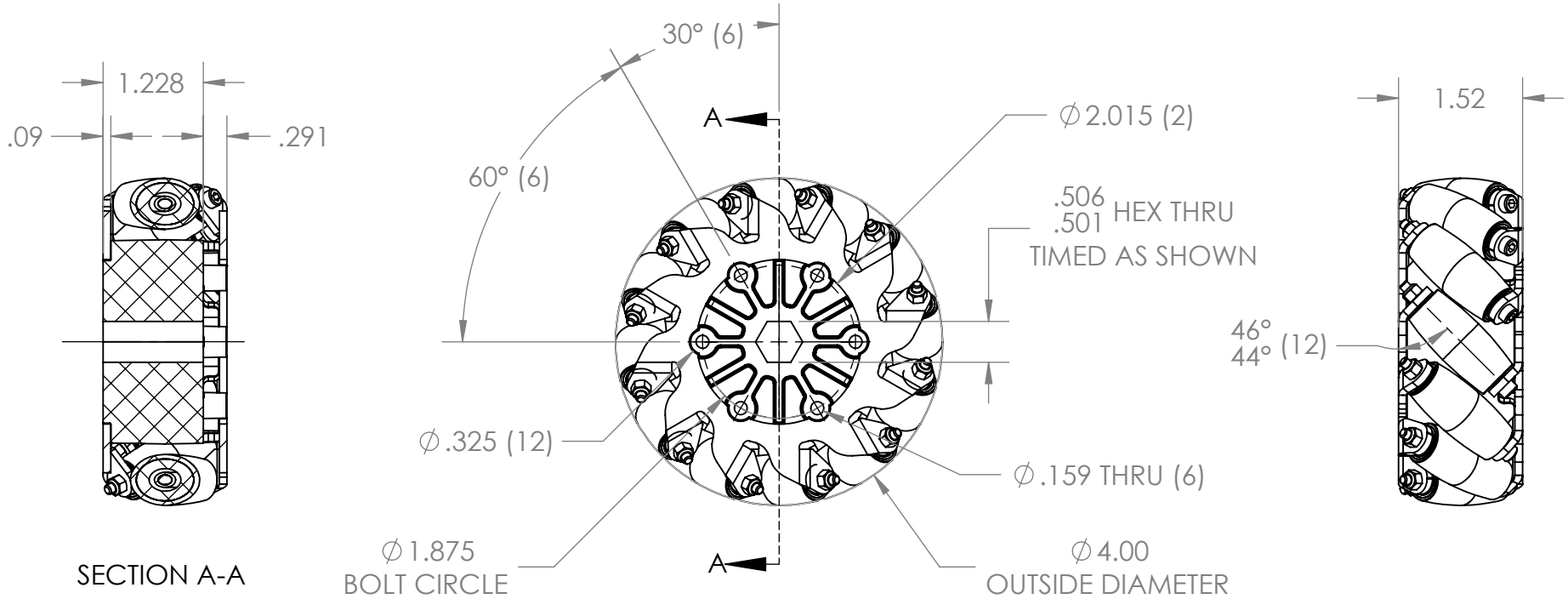

REVISION HISTORY			
REV.	DESCRIPTION	DATE	DRAWN BY
1	ORIGINAL PRINT	7/28/2022	P. YEUNG



*** SEE CAD FOR ADDITIONAL TOOLPATH INFO***

UNLESS OTHERWISE SPECIFIED:		COMMENTS:					
DIMENSIONS ARE IN INCHES		DUAL DIMENSIONS ARE IN MILLIMETERS.					
TOLERANCES: FRACTIONAL ±1/16 ANGULAR: MACH ±1° ANGULAR: BEND ±5° ONE PLACE DECIMAL ±0.1 TWO PLACE DECIMAL ±0.01 THREE PLACE DECIMAL ±0.005 FOUR PLACE DECIMAL ±0.0005		BREAK ALL SHARP EDGES.		TITLE: 4IN BALL BEARING MECANUM WHEEL 500IN HEX BORE LEFT			
MATERIAL VARIOUS		CHECKED	NAME NL	DATE	SIZE	DWG. NO.	REV
FINISH		ENG APPR.		7/29/22	A	am-4736L	1
DO NOT SCALE DRAWING		MFG APPR.			SCALE: 1:2		SHEET 1 OF 1
		Q.A.					

