

4

3

2

1

REVISION HISTORY			
REV.	DESCRIPTION	DATE	DRAWN BY
1	ORIGINAL PRINT	9/2/2022	N. LAWRENCE

B

B

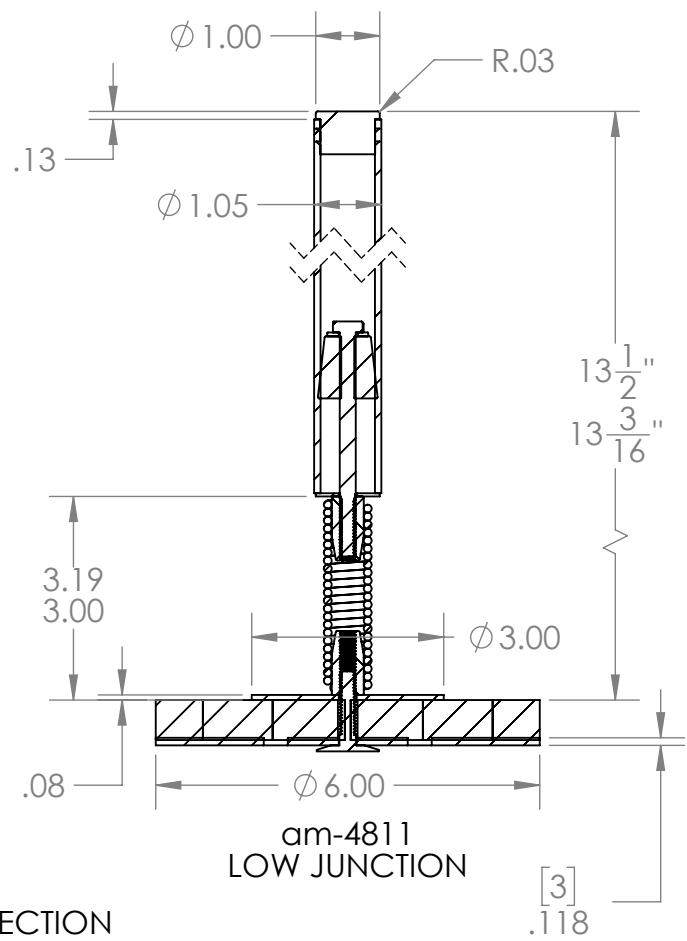
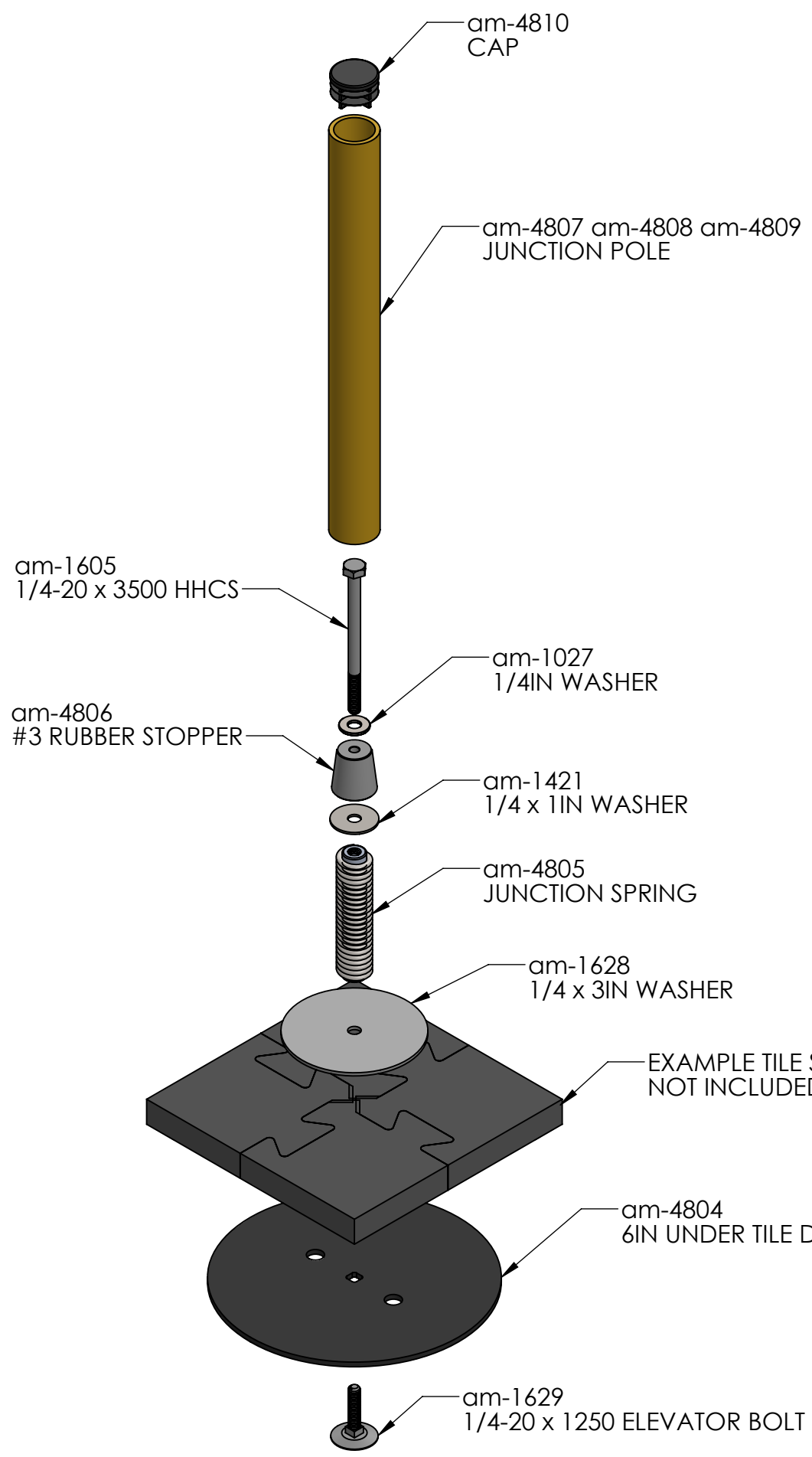

am-4811
LOW JUNCTION
SECTION VIEW
SCALE 1:3

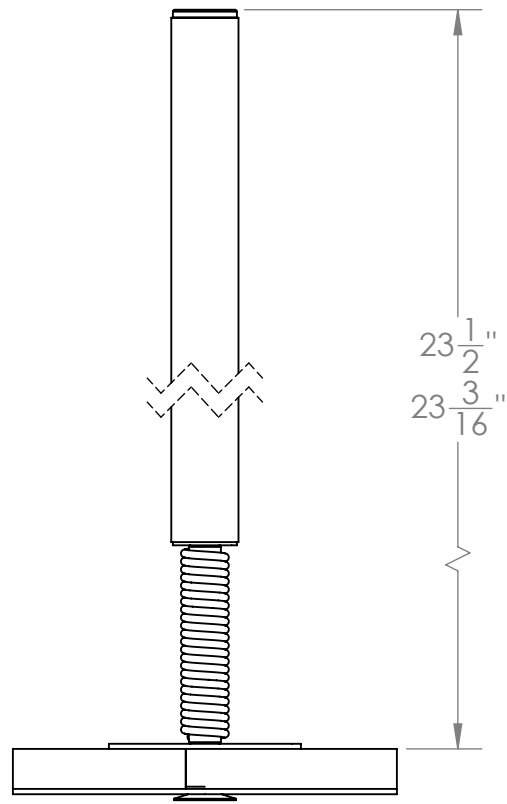

am-4812
MEDIUM JUNCTION

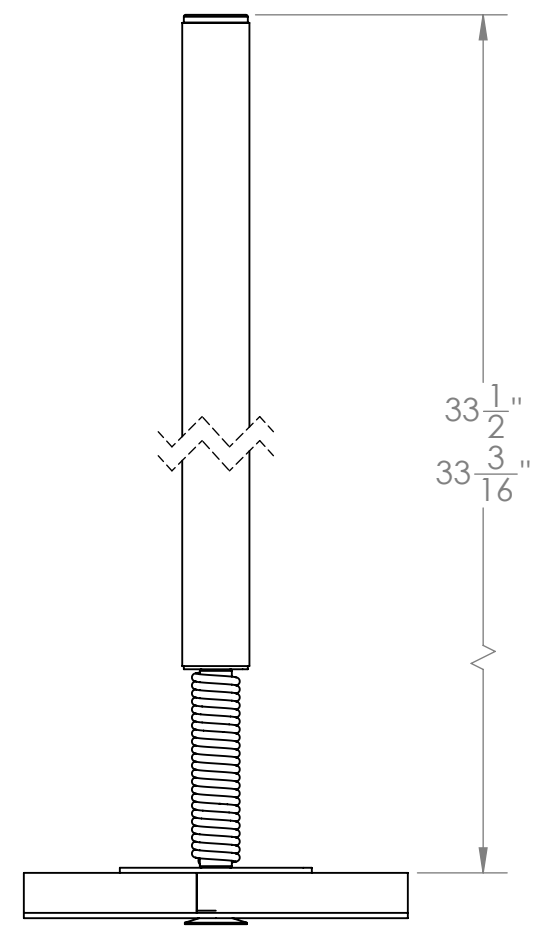

am-4813
HIGH JUNCTION

A

A

*** SEE CAD FOR ADDITIONAL TOOLPATH INFO***

UNLESS OTHERWISE SPECIFIED:		COMMENTS:					
DIMENSIONS ARE IN INCHES		DUAL DIMENSIONS ARE IN MILLIMETERS.					
TOLERANCES:		BREAK ALL SHARP EDGES.		SIZE	DWG. NO.	am-4811	REV
FRACTIONAL	±1/16			B		am-4812	1
ANGULAR: MACH	±1°			SCALE: 1:8		am-4813	
ANGULAR: BEND	±5°			SHEET 1 OF 1			
ONE PLACE DECIMAL	±0.1						
TWO PLACE DECIMAL	±0.01						
THREE PLACE DECIMAL	±0.005						
FOUR PLACE DECIMAL	±0.0005						
MATERIAL	VARIOUS	CHECKED	NAME	DATE			
FINISH		ENG APPR.	NM	9/7/22			
		MFG APPR.					
		Q.A.					
DO NOT SCALE DRAWING							

4

3

2

1