

4

3

2

1

REVISION HISTORY			
REV.	DESCRIPTION	DATE	DRAWN BY
1	ORIGINAL PRINT	12/6/2021	N. LAWRENCE
2	REPLACED MULTI-PIECE SPOOL WITH SINGLE PIECE	9/20/2022	N. LAWRENCE

B

B

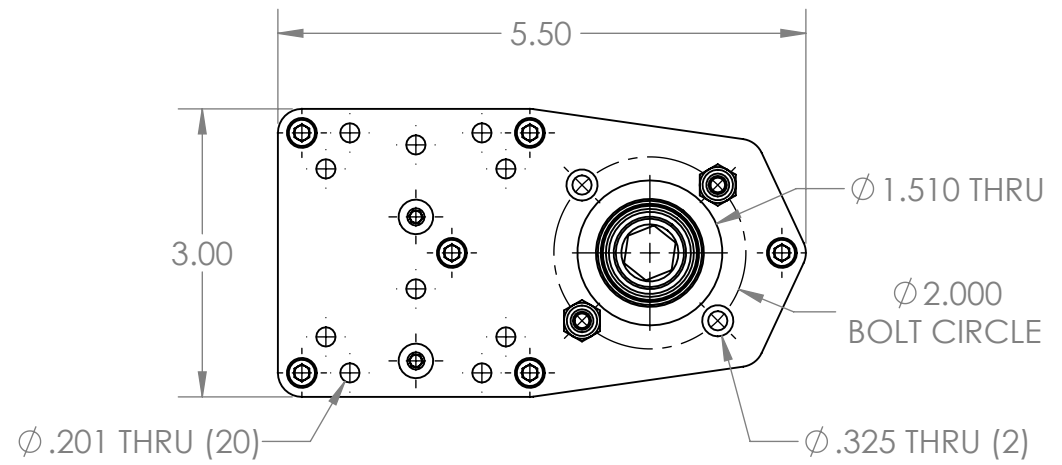
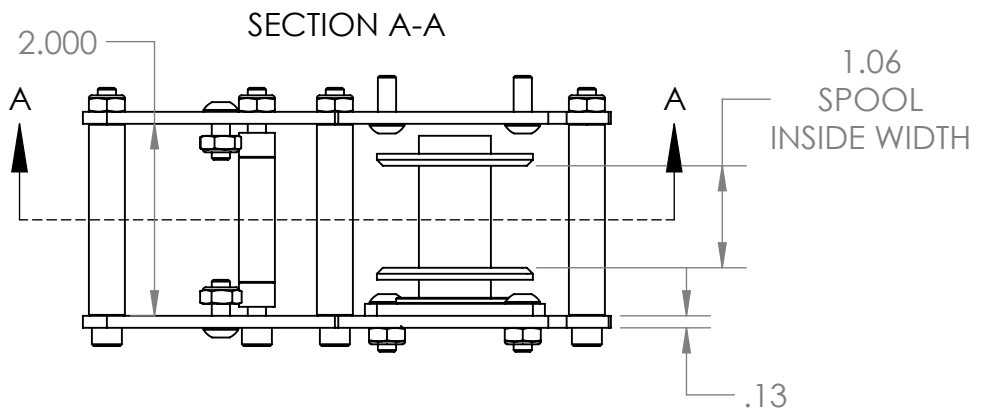
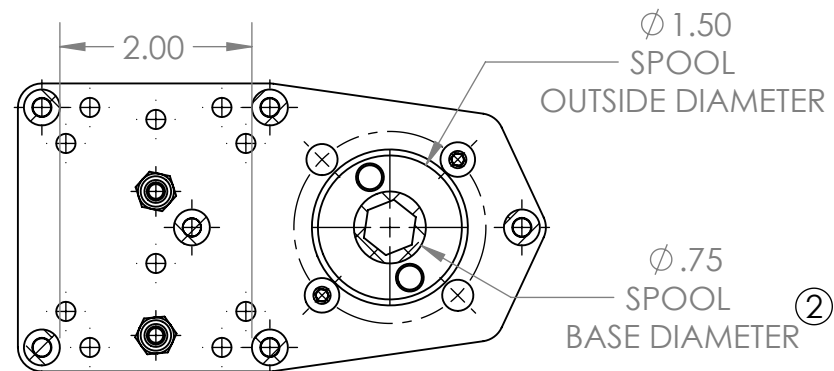
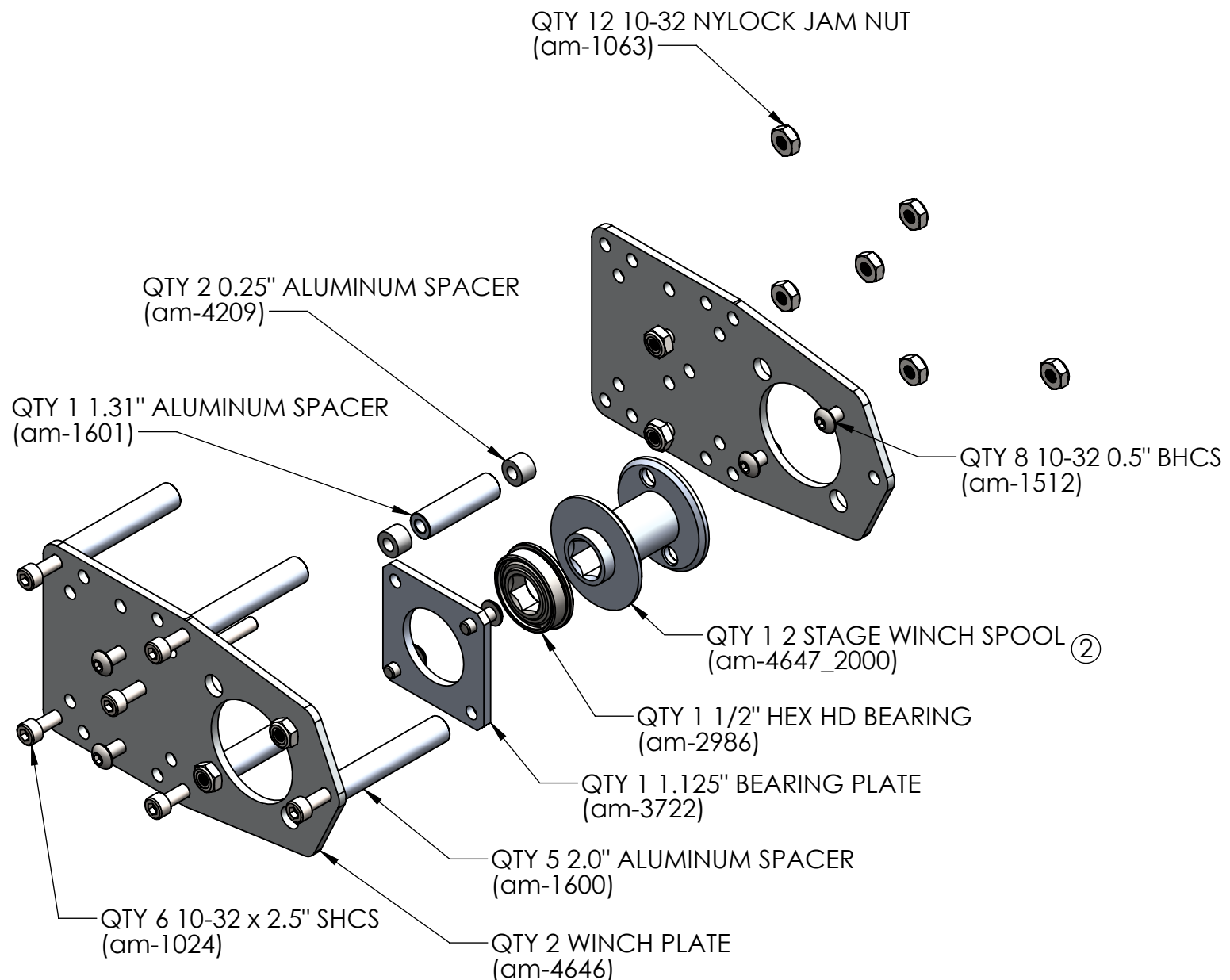

A

A

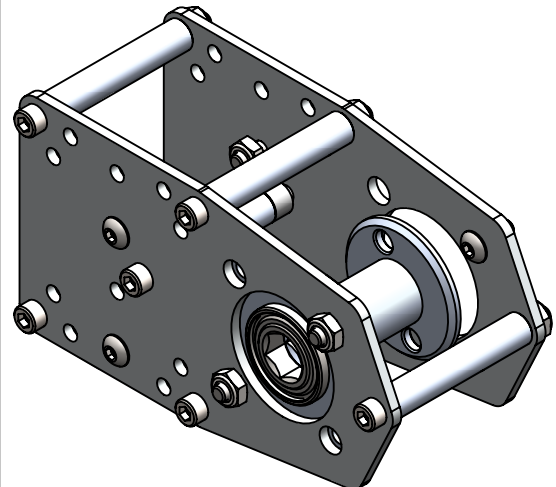

ALSO INCLUDED:  
 QTY 1 1/8" UHMW-PE ROPE (am-4559)

\*\*\* SEE CAD FOR ADDITIONAL TOOLPATH INFO\*\*\*

UNLESS OTHERWISE SPECIFIED:		COMMENTS:				
<b>DIMENSIONS ARE IN INCHES</b>		DUAL DIMENSIONS ARE IN MILLIMETERS.				
TOLERANCES:		BREAK ALL SHARP EDGES.		SIZE	DWG. NO.	REV
FRACTIONAL	±1/16			<b>B</b>	am-4664	2
ANGULAR: MACH	±1°			SCALE: 1:2 SHEET 1 OF 1		
ANGULAR: BEND	±5°					
ONE PLACE DECIMAL	±0.1					
TWO PLACE DECIMAL	±0.01					
THREE PLACE DECIMAL	±0.005					
FOUR PLACE DECIMAL	±0.0005					
MATERIAL	VARIOUS	CHECKED	NAME	DATE		
FINISH	DEBURRED	ENG APPR.	NM	10/5/22		
DO NOT SCALE DRAWING		MFG APPR.				
		Q.A.				

4

3

2

1