

4

3

2

1

REVISION HISTORY			
REV.	DESCRIPTION	DATE	DRAWN BY
1	ORIGINAL PRINT	6/30/2022	P. YEUNG

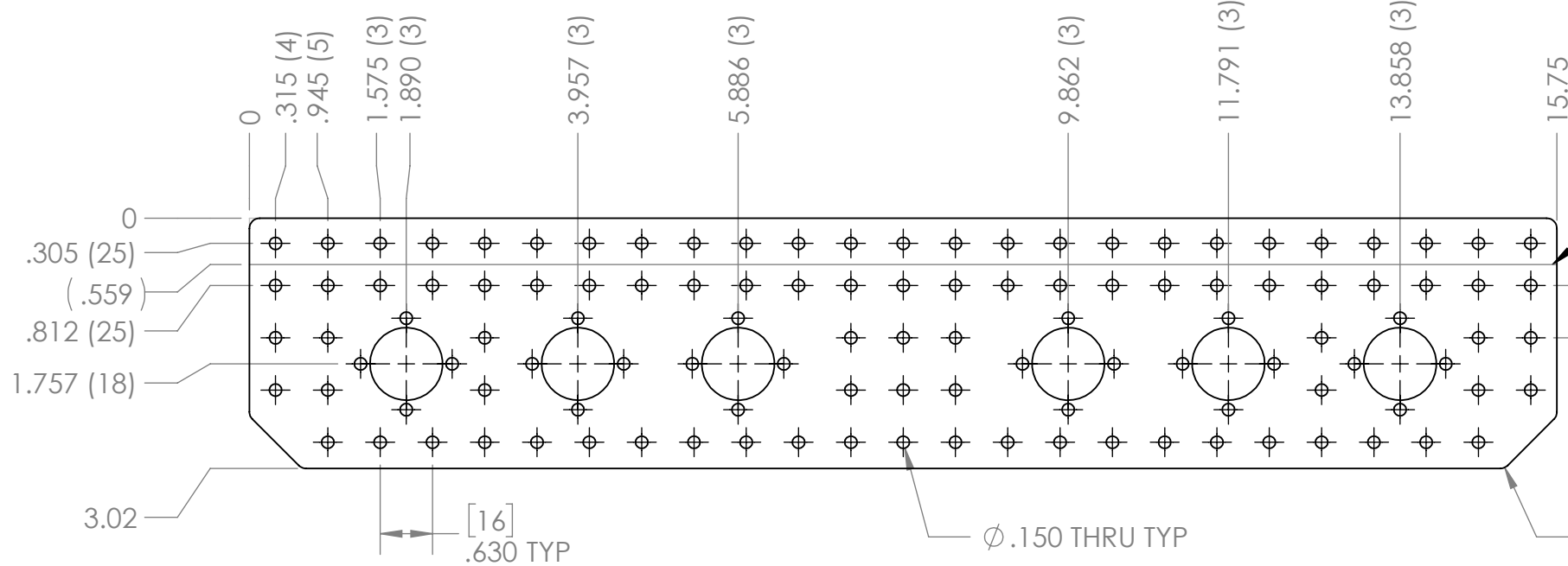

UP 90° R.03

[16] .630 TYP

R.13 (6)

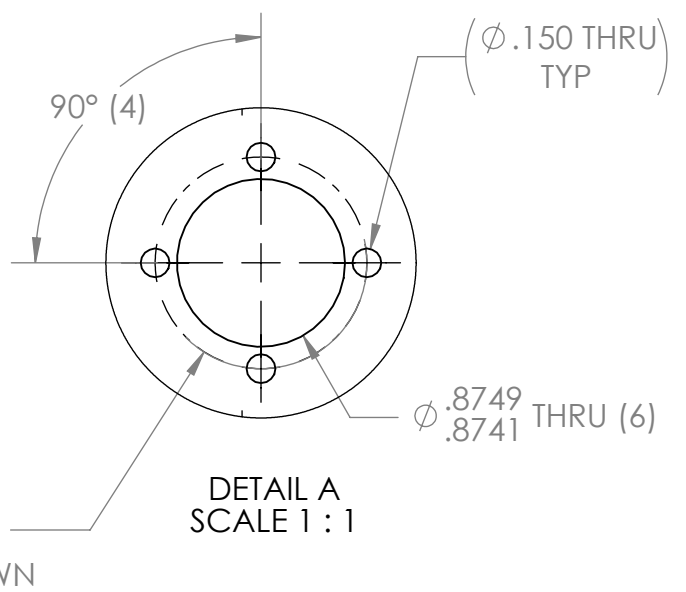

[28]
 Ø 1.102
 BOLT CIRCLE
 TIMED AS SHOWN

DETAIL A
SCALE 1:1

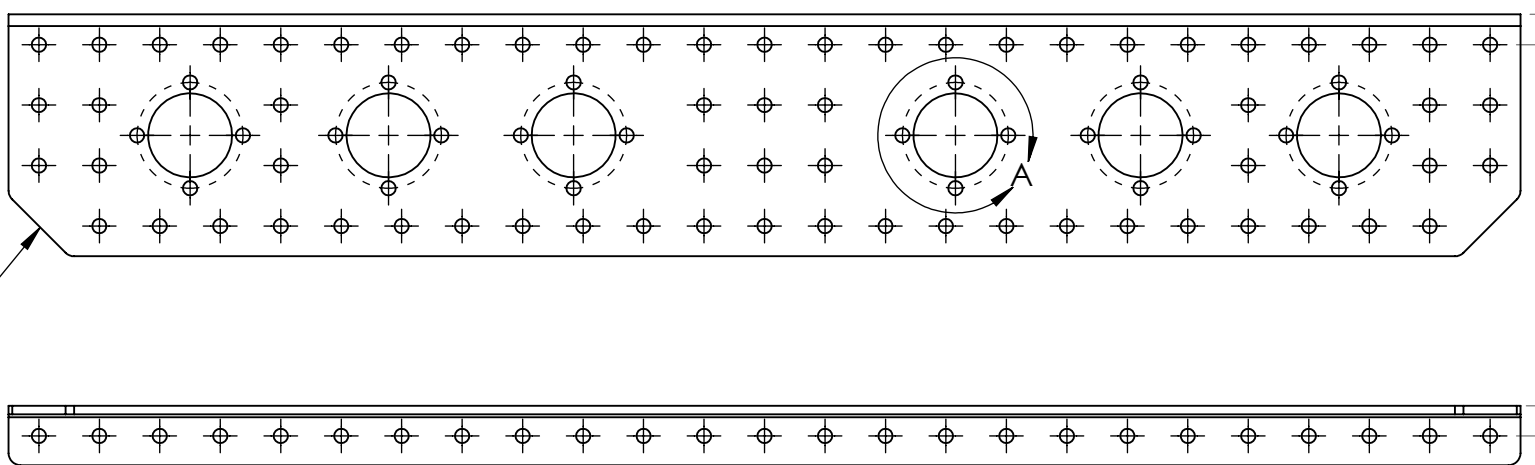

[8] .315 TYP

[8] .315 TYP

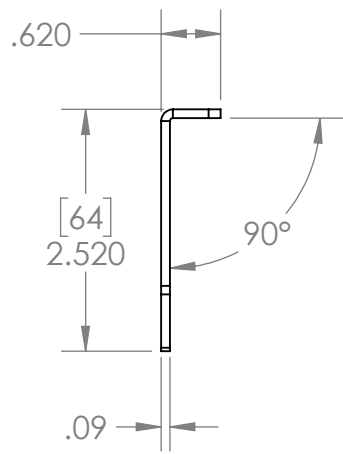

[64] 2.520

.09

*** SEE CAD FOR ADDITIONAL TOOLPATH INFO***

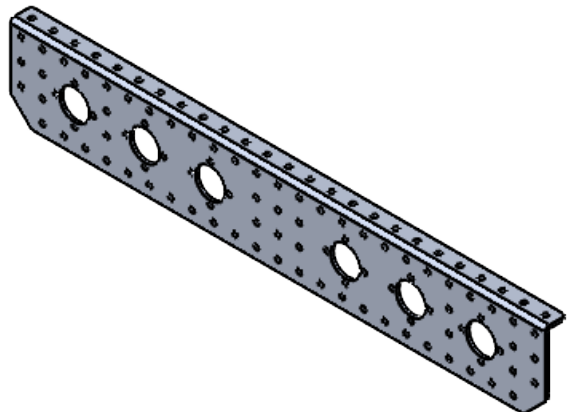

UNLESS OTHERWISE SPECIFIED:		COMMENTS:				
DIMENSIONS ARE IN INCHES		DUAL DIMENSIONS ARE IN MILLIMETERS.				
TOLERANCES:		BREAK ALL SHARP EDGES.		TITLE:		
FRACTIONAL	±1/16			MECANAM		
ANGULAR: MACH	±1°			SIDE PLATE		
ANGULAR: BEND	±5°			SIZE		
ONE PLACE DECIMAL	±0.1			B	DWG. NO.	REV
TWO PLACE DECIMAL	±0.01				am-4760	1
THREE PLACE DECIMAL	±0.005			SCALE: 1:2		
FOUR PLACE DECIMAL	±0.0005			SHEET 1 OF 1		
MATERIAL	5052 AL	CHECKED	NAME	DATE		
FINISH	DEBURRED	ENG APPR.	NL	7/5/22		
DO NOT SCALE DRAWING		MFG APPR.				
		Q.A.				

4

3

2

1