

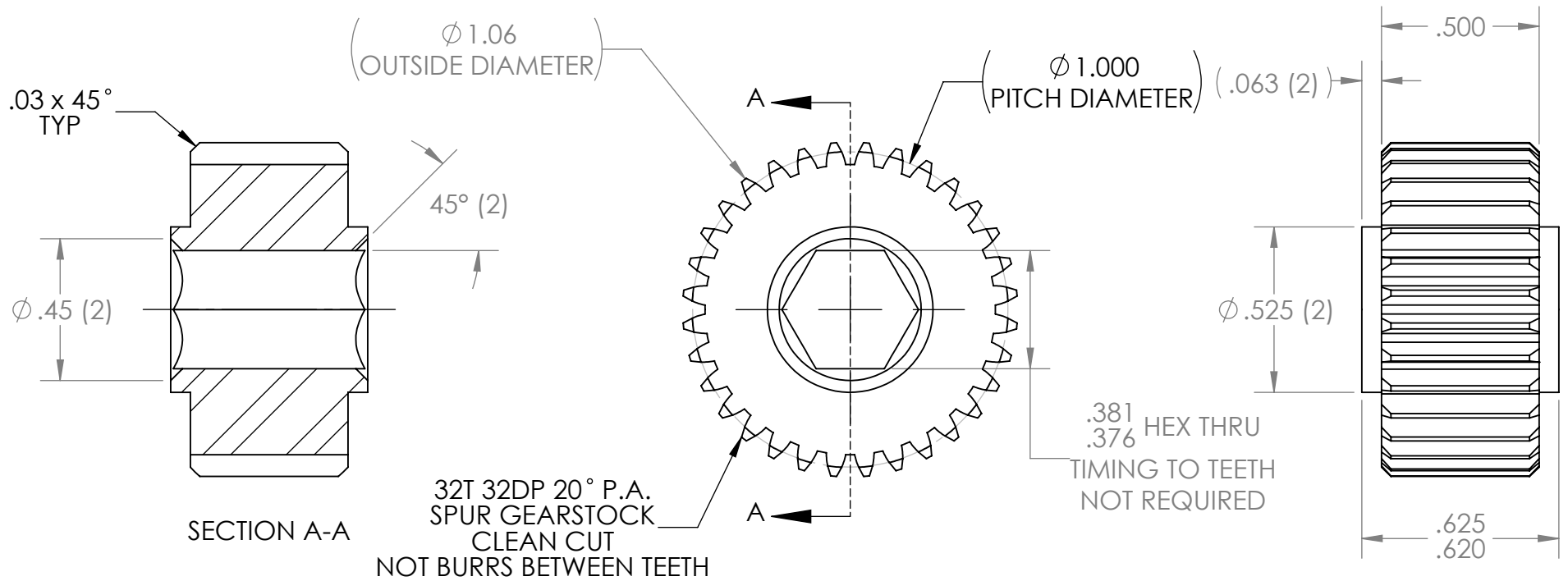

REVISION HISTORY			
REV.	DESCRIPTION	DATE	DRAWN BY
1	ORIGINAL PRINT	6/10/2022	T. JORGENSEN

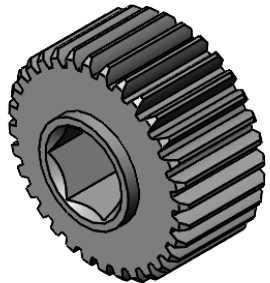

*** SEE CAD FOR ADDITIONAL TOOLPATH INFO***



UNLESS OTHERWISE SPECIFIED:		COMMENTS:				
DIMENSIONS ARE IN INCHES		DUAL DIMENSIONS ARE IN MILLIMETERS.				
TOLERANCES:		BREAK ALL SHARP EDGES.		TITLE:		
FRACTIONAL	±1/16			32T 32DP 20PA		
ANGULAR: MACH	±1°			375IN HEX BORE GEAR		
ANGULAR: BEND	±5°					
ONE PLACE DECIMAL	±0.1					
TWO PLACE DECIMAL	±0.01	MATERIAL		SIZE	DWG. NO.	REV
THREE PLACE DECIMAL	±0.005	1117 STEEL		A	am-4326	1
FOUR PLACE DECIMAL	±0.0005	FINISH		SCALE: 2:1		
DEBURRED		CHECKED		SHEET 1 OF 1		
ZINC PLATED		ENG APPR.				
DO NOT SCALE DRAWING		MFG APPR.				
		Q.A.				