

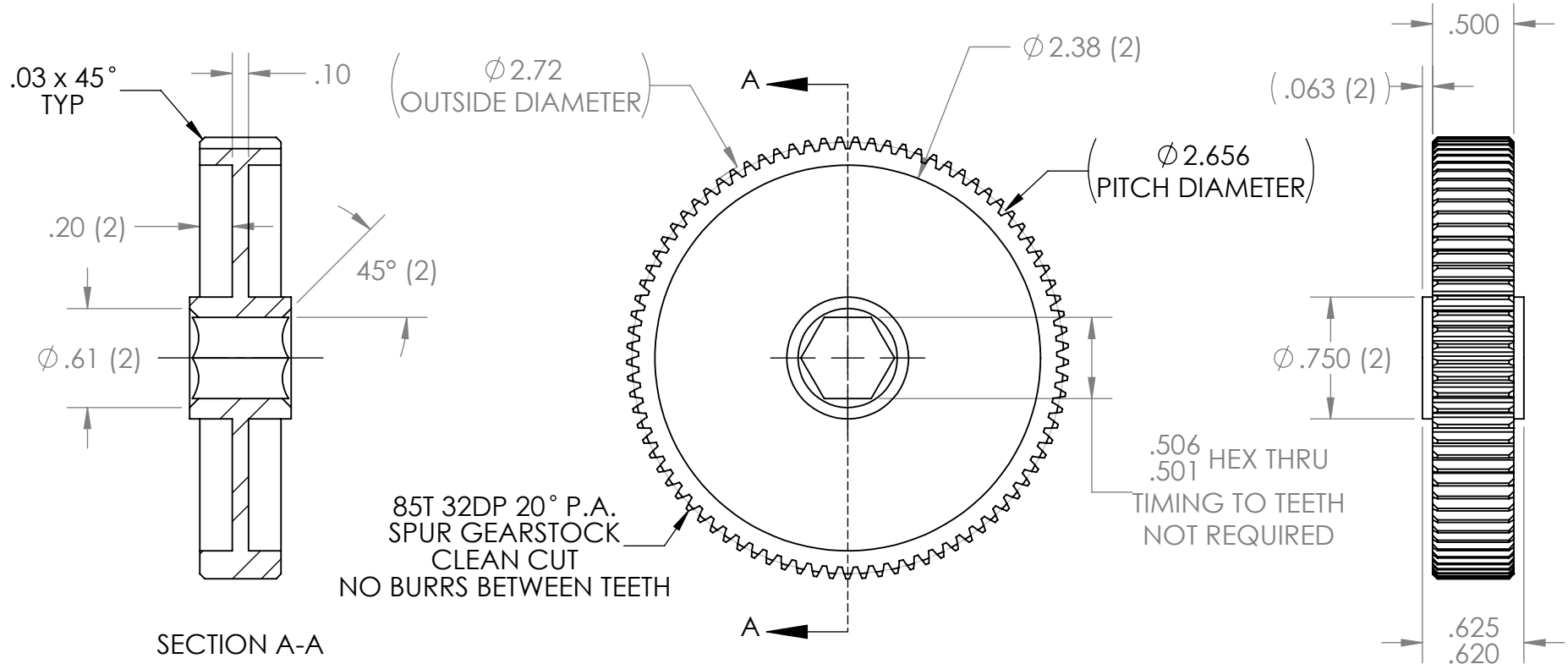

REVISION HISTORY			
REV.	DESCRIPTION	DATE	DRAWN BY
1	ORIGINAL PRINT	6/9/2022	T. JORGENSEN

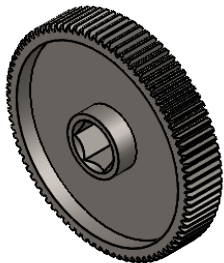

SECTION A-A

\*\*\* SEE CAD FOR ADDITIONAL TOOLPATH INFO\*\*\*



UNLESS OTHERWISE SPECIFIED:		COMMENTS:		TITLE:			
<b>DIMENSIONS ARE IN INCHES</b>		DUAL DIMENSIONS ARE IN MILLIMETERS.		 <b>85T 32DP 20PA</b> <b>500IN HEX BORE GEAR</b>			
TOLERANCES: FRACTIONAL $\pm 1/16$ ANGULAR: MACH $\pm 1^\circ$ ANGULAR: BEND $\pm 5^\circ$ ONE PLACE DECIMAL $\pm 0.1$ TWO PLACE DECIMAL $\pm 0.01$ THREE PLACE DECIMAL $\pm 0.005$ FOUR PLACE DECIMAL $\pm 0.0005$		BREAK ALL SHARP EDGES.					
MATERIAL 4140 STEEL		CHECKED	NAME NL	DATE	SIZE	DWG. NO.	REV
FINISH DEBURRED ZINC PLATED		ENG APPR.		6/10/22	<b>A</b>	<b>am-4335</b>	<b>1</b>
DO NOT SCALE DRAWING		MFG APPR.			SCALE: 1:1		SHEET 1 OF 1
		Q.A.					