

4

3

2

1

REVISION HISTORY			
REV.	DESCRIPTION	DATE	DRAWN BY
1	ORIGINAL PRINT	12/7/2022	N. LAWRENCE

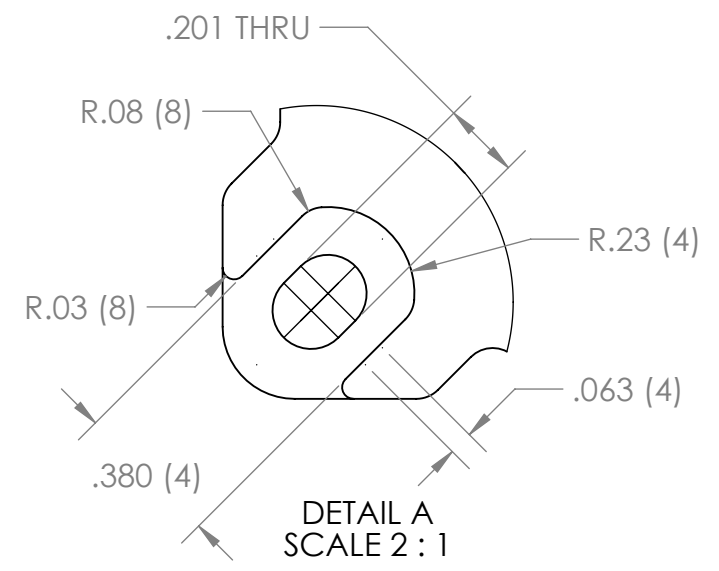
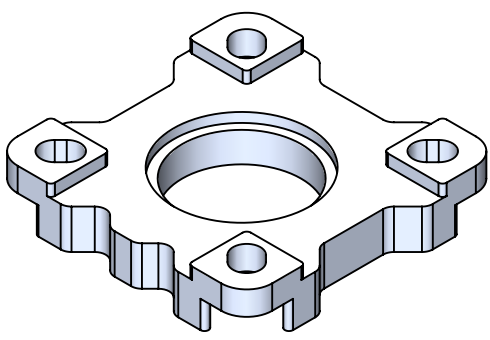
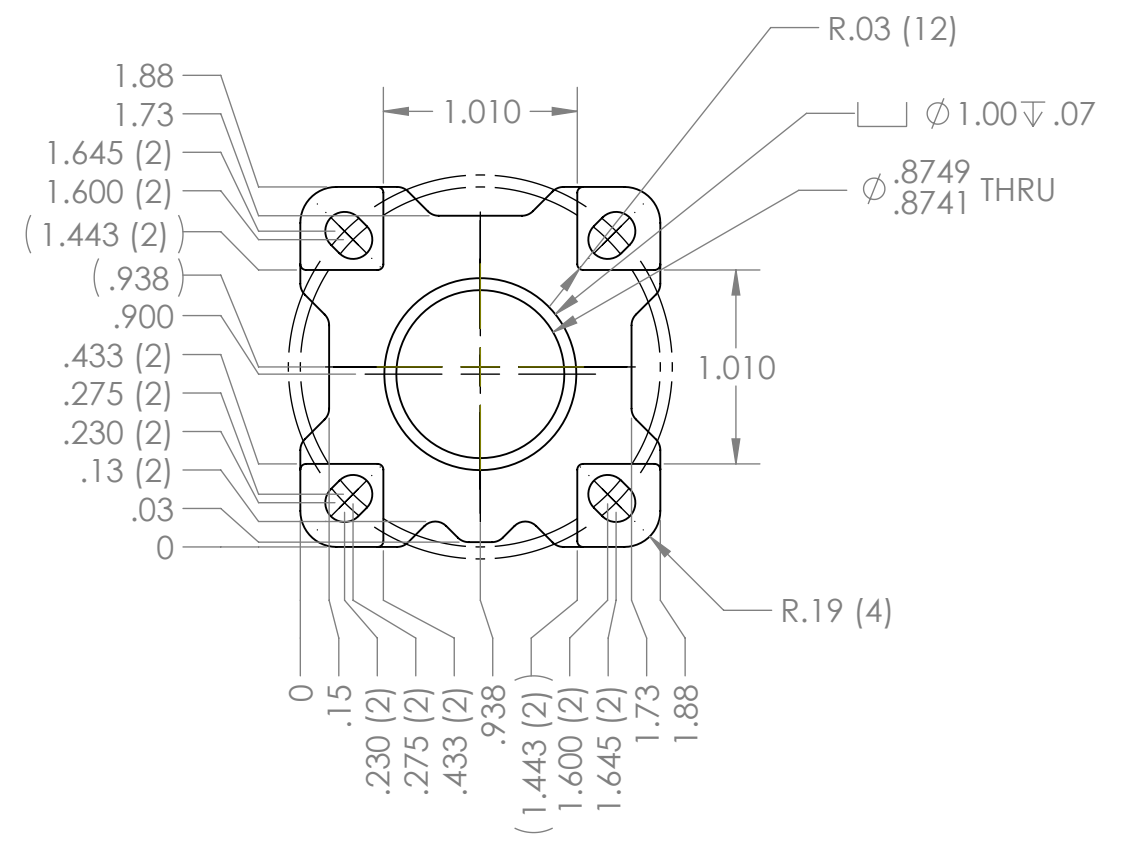
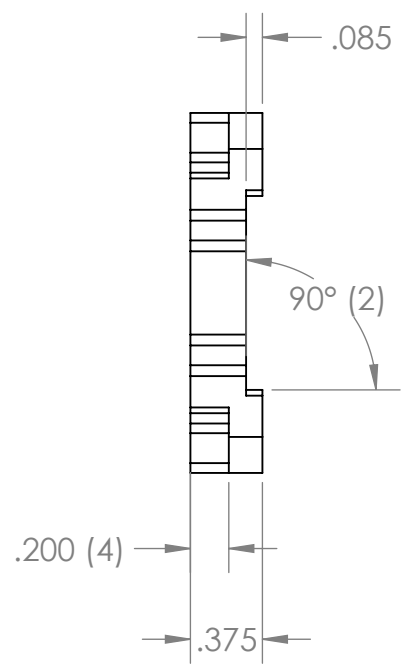
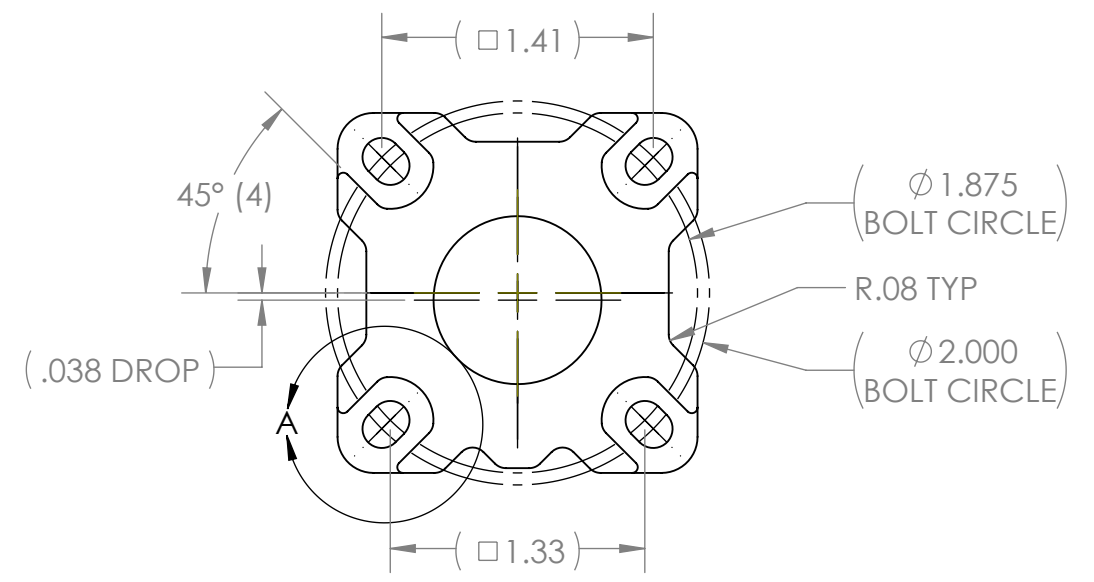
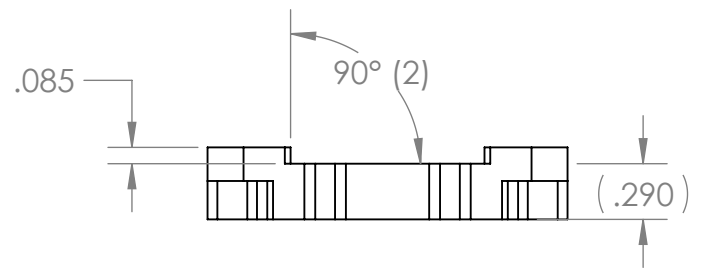

*** SEE CAD FOR ADDITIONAL TOOLPATH INFO***

UNLESS OTHERWISE SPECIFIED:		COMMENTS:				
DIMENSIONS ARE IN INCHES		DUAL DIMENSIONS ARE IN MILLIMETERS.				
TOLERANCES:		BREAK ALL SHARP EDGES.		1x1 875IN BEARING BLOCK		
FRACTIONAL	±1/16			SIZE	DWG. NO.	REV
ANGULAR: MACH	±1°			B	am-4937	1
ANGULAR: BEND	±5°			SCALE: 1:1 SHEET 1 OF 1		
ONE PLACE DECIMAL	±0.1					
TWO PLACE DECIMAL	±0.01					
THREE PLACE DECIMAL	±0.005					
FOUR PLACE DECIMAL	±0.0005					
MATERIAL	6061-T6 AL	CHECKED	NAME	DATE		
FINISH	DEBURRED	ENG APPR.	NM	12/8/22		
DO NOT SCALE DRAWING		MFG APPR.				
		Q.A.				

4

3

2

1

B

B

A

A