

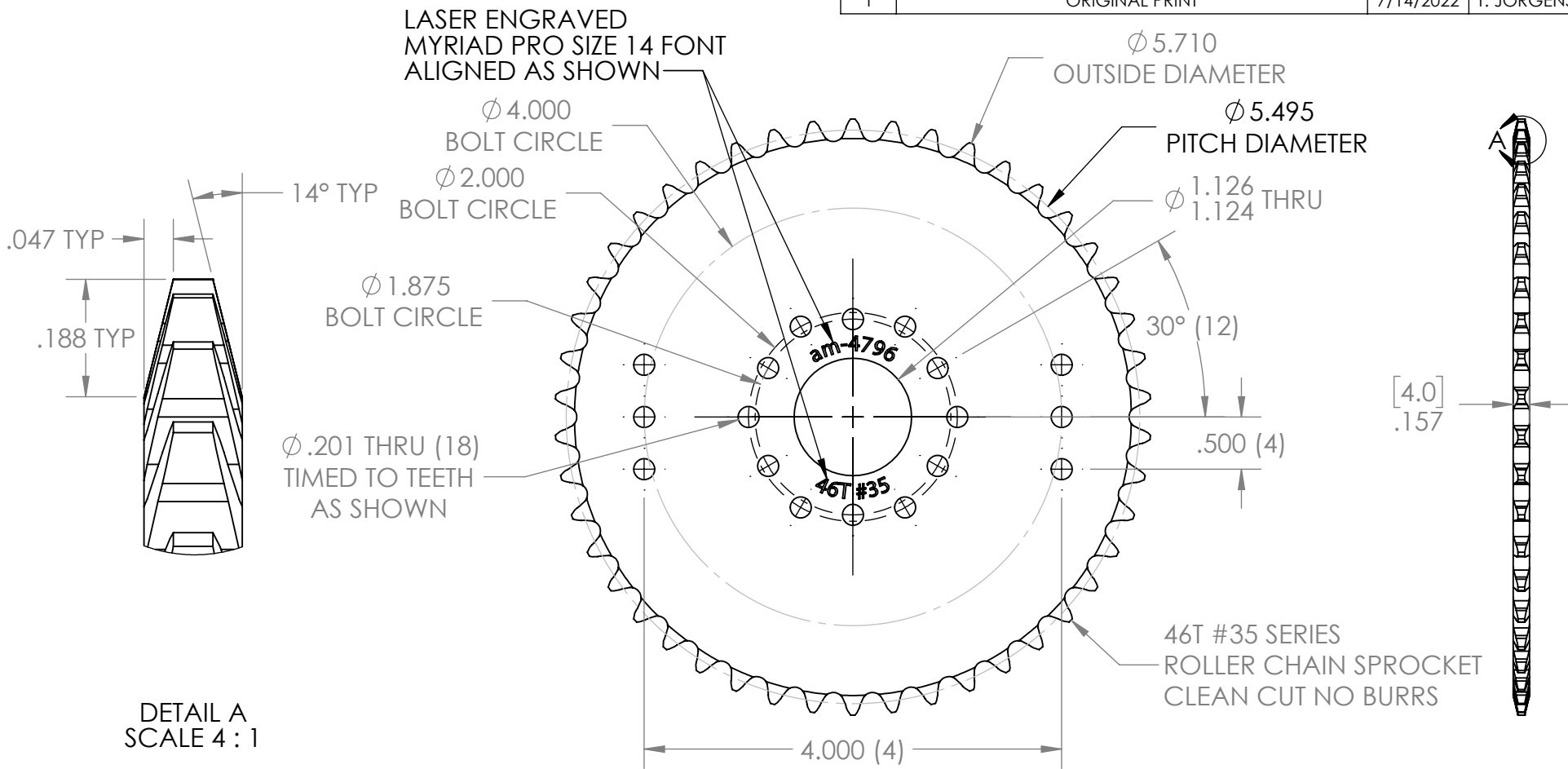

REVISION HISTORY			
REV.	DESCRIPTION	DATE	DRAWN BY
1	ORIGINAL PRINT	7/14/2022	T. JORGENSEN



*** SEE CAD FOR ADDITIONAL TOOLPATH INFO***

UNLESS OTHERWISE SPECIFIED:		COMMENTS:																
DIMENSIONS ARE IN INCHES		DUAL DIMENSIONS ARE IN MILLIMETERS.																
TOLERANCES:		BREAK ALL SHARP EDGES.		TITLE: 46T 35 CHAIN 1125 IN BORE PLATE SPROCKET														
FRACTIONAL	±1/16	<table border="1"> <tr> <td>CHECKED</td> <td>NAME</td> <td>DATE</td> </tr> <tr> <td>ENG APPR.</td> <td>NL</td> <td>7/29/22</td> </tr> <tr> <td>MFG APPR.</td> <td></td> <td></td> </tr> <tr> <td>Q.A.</td> <td></td> <td></td> </tr> </table>		CHECKED	NAME	DATE	ENG APPR.	NL	7/29/22	MFG APPR.			Q.A.			SIZE	DWG. NO.	REV
CHECKED	NAME			DATE														
ENG APPR.	NL			7/29/22														
MFG APPR.																		
Q.A.																		
ANGULAR: MACH	±1°	A	am-4796	1														
ANGULAR: BEND	±5°	SCALE: 1:1.5 SHEET 1 OF 1																
ONE PLACE DECIMAL	±0.1																	
TWO PLACE DECIMAL	±0.01																	
THREE PLACE DECIMAL	±0.005																	
FOUR PLACE DECIMAL	±0.0005																	
MATERIAL	7075-T6 AL																	
FINISH	DEBURRED SILVER ANODIZED																	
DO NOT SCALE DRAWING																		

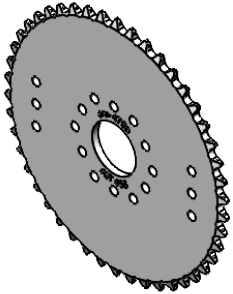

5

4

3

2

1