

REV.	DESCRIPTION	DATE	DRAWN BY
1	ORIGINAL PRINT	10/20/2022	N. LAWRENCE

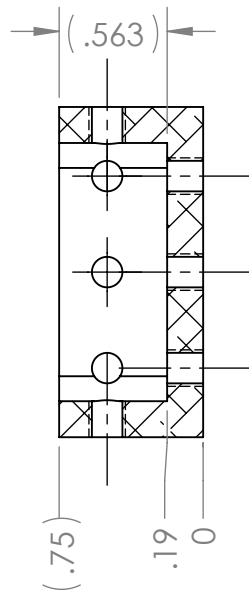

SECTION A-A

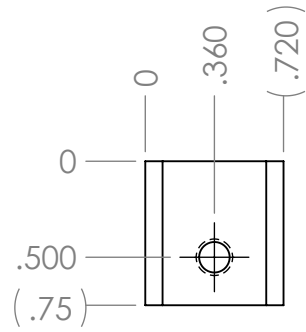
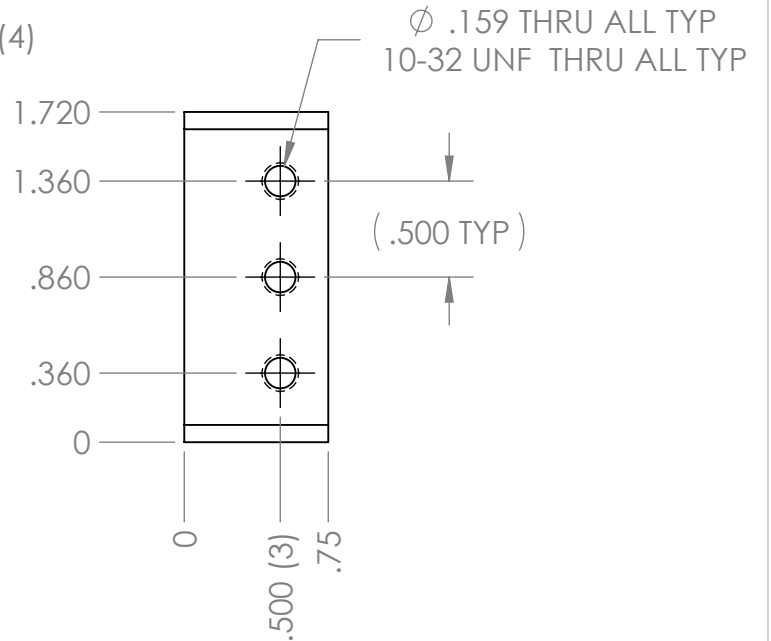
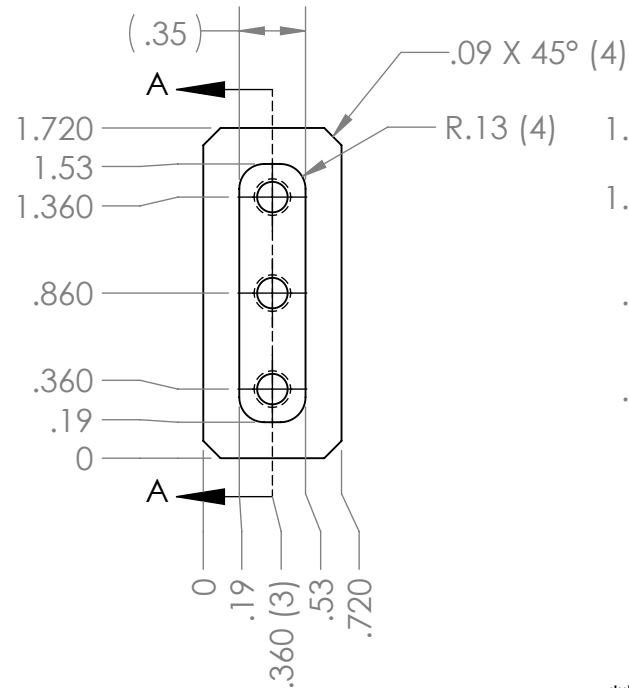

*** SEE CAD FOR ADDITIONAL TOOLPATH INFO***

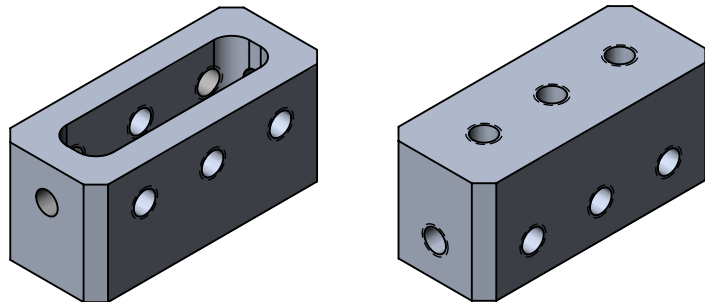

UNLESS OTHERWISE SPECIFIED:		COMMENTS:	
DIMENSIONS ARE IN INCHES		DUAL DIMENSIONS ARE IN MILLIMETERS.	
TOLERANCES:		BREAK ALL SHARP EDGES.	
FRACTIONAL	±1/16		
ANGULAR: MACH	±1°		
ANGULAR: BEND	±5°		
ONE PLACE DECIMAL	±0.1		
TWO PLACE DECIMAL	±0.01		
THREE PLACE DECIMAL	±0.005		
FOUR PLACE DECIMAL	±0.0005		
MATERIAL	6061-T6 AL	NAME	DATE
FINISH	TUMBLER	CHECKED	NM 10/20/22
DO NOT SCALE DRAWING		ENG APPR.	
		MFG APPR.	
		Q.A.	



TITLE:
TUBE PLUG FOR
2x1x125IN WALL

SIZE	DWG. NO.	REV
A	am-4762	1
SCALE: 1:1		SHEET 1 OF 1