

REVISION HISTORY			
REV.	DESCRIPTION	DATE	DRAWN BY
1	ORIGINAL PRINT	5/3/2023	P. YEUNG

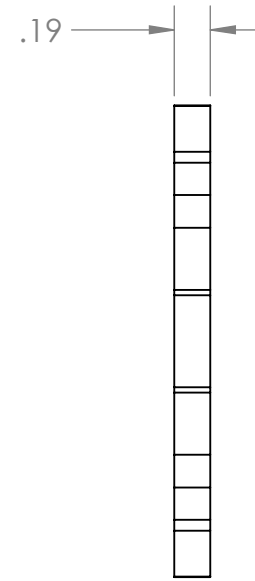

*** SEE CAD FOR ADDITIONAL TOOLPATH INFO***

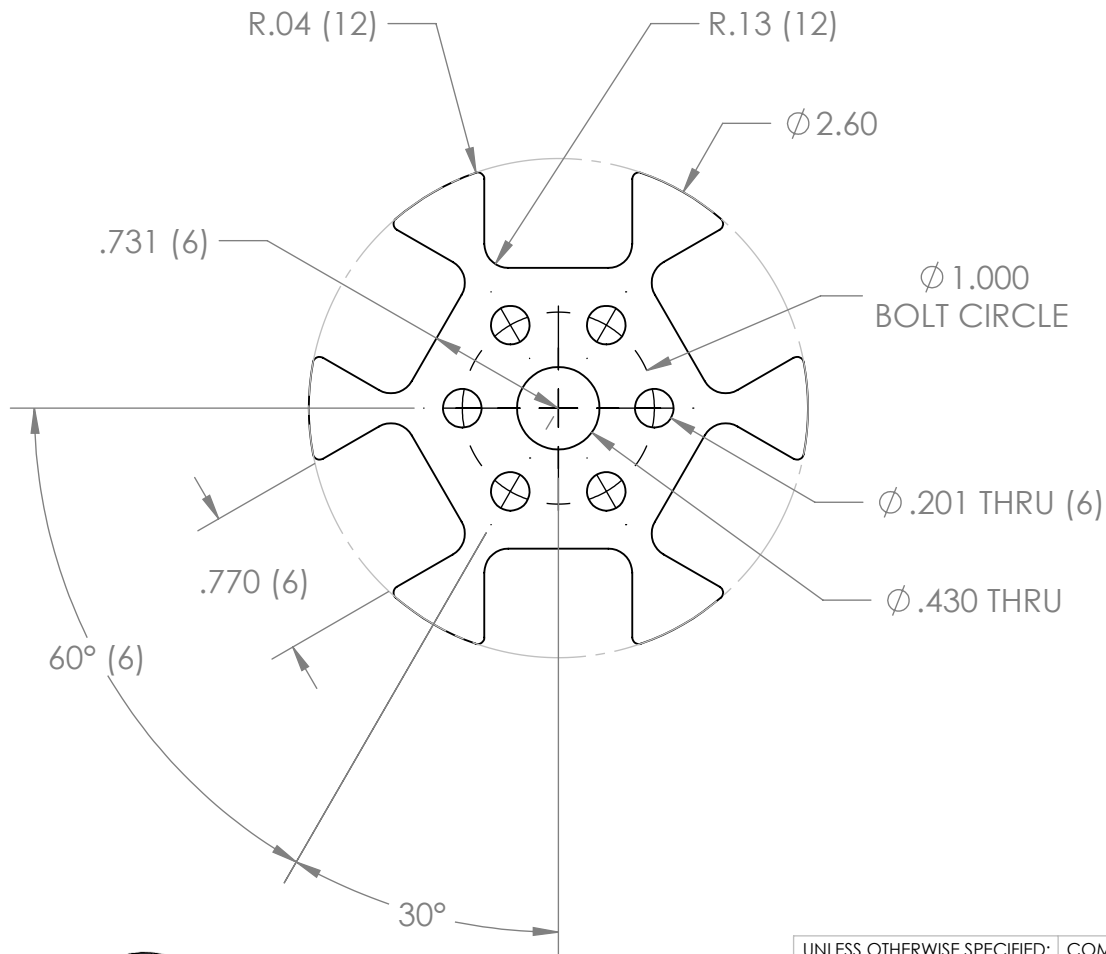
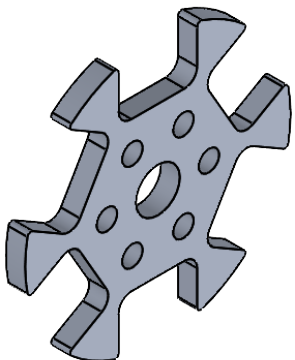

UNLESS OTHERWISE SPECIFIED:		COMMENTS:			
DIMENSIONS ARE IN INCHES		DUAL DIMENSIONS ARE IN MILLIMETERS.			
TOLERANCES:		BREAK ALL SHARP EDGES.		TITLE:	
FRACTIONAL	±1/16			3IN ALUMINUM OMNI WHEEL	
ANGULAR: MACH	±1°			OUTER PLATE	
ANGULAR: BEND	±5°				
ONE PLACE DECIMAL	±0.1			SIZE	DWG. NO.
TWO PLACE DECIMAL	±0.01			A	am-4967_outer
THREE PLACE DECIMAL	±0.005				1
FOUR PLACE DECIMAL	±0.0005			SCALE: 1:1	SHEET 1 OF 1
MATERIAL	AL 6061-T6	CHECKED	NAME	DATE	
FINISH	DEBURRED	ENG APPR.	NM	5/5/23	
DO NOT SCALE DRAWING		MFG APPR.			
		Q.A.			