

4

3

2

1

REVISION HISTORY			
REV.	DESCRIPTION	DATE	DRAWN BY
1	ORIGINAL PRINT	3/20/2023	P. YEUNG
2	MATERIAL CHANGE	6/20/2023	P. YEUNG

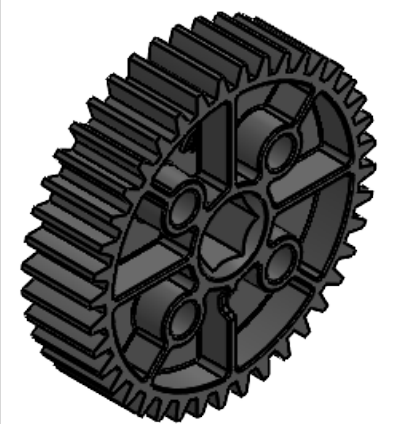
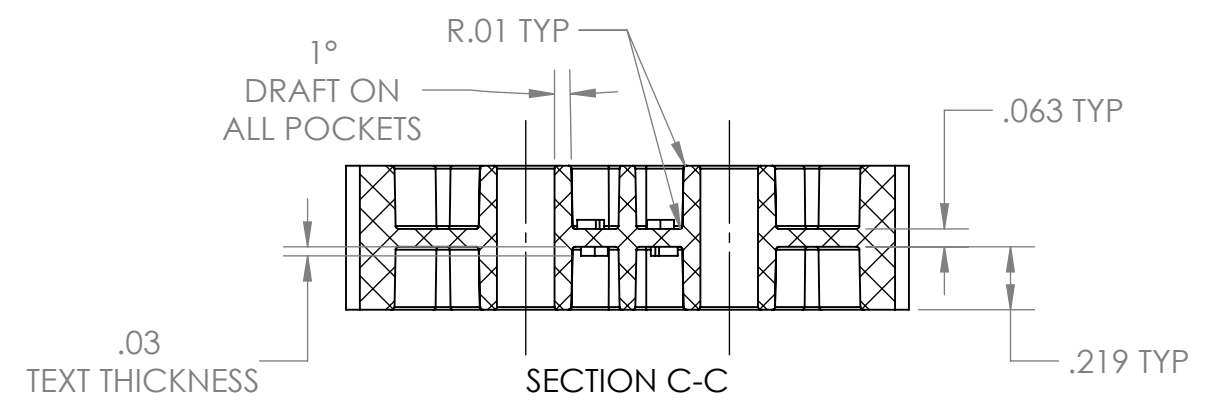
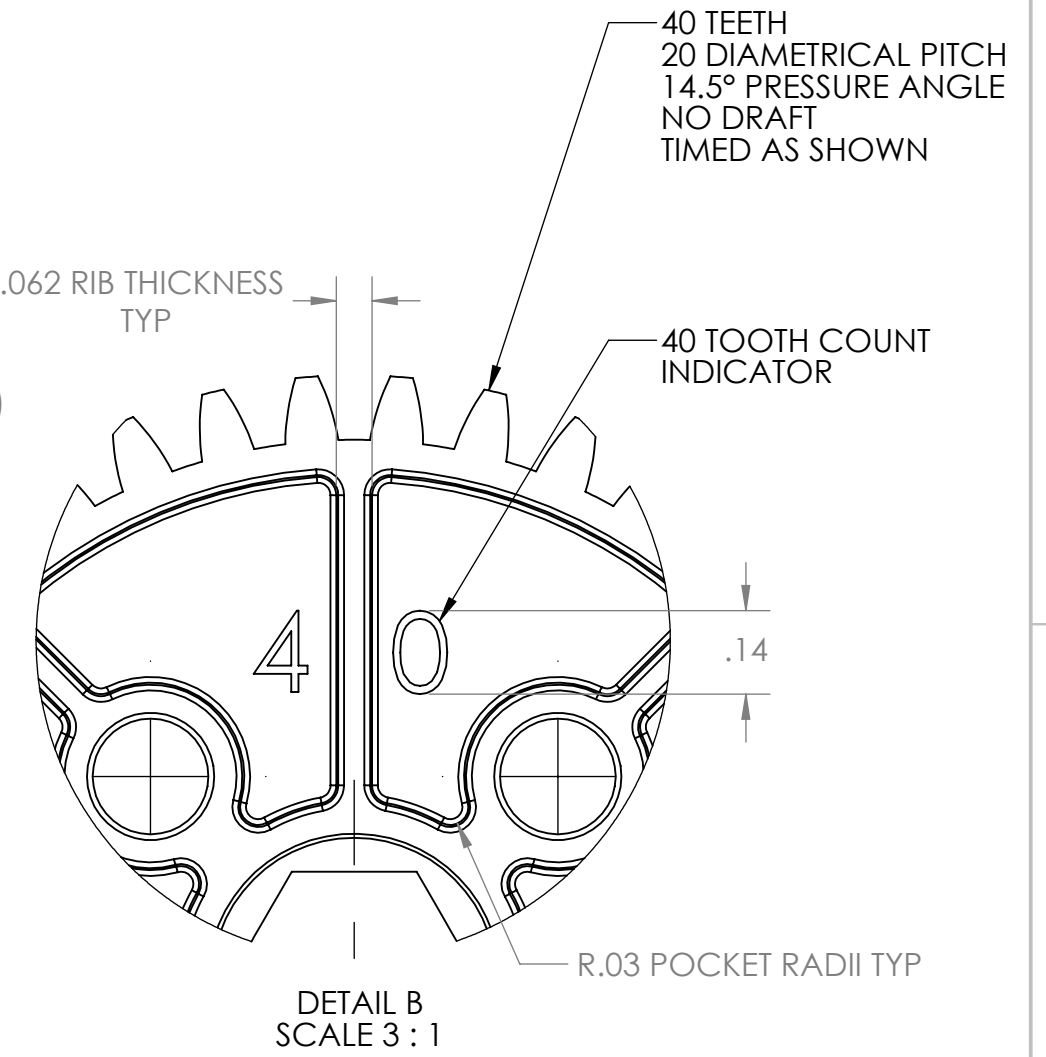
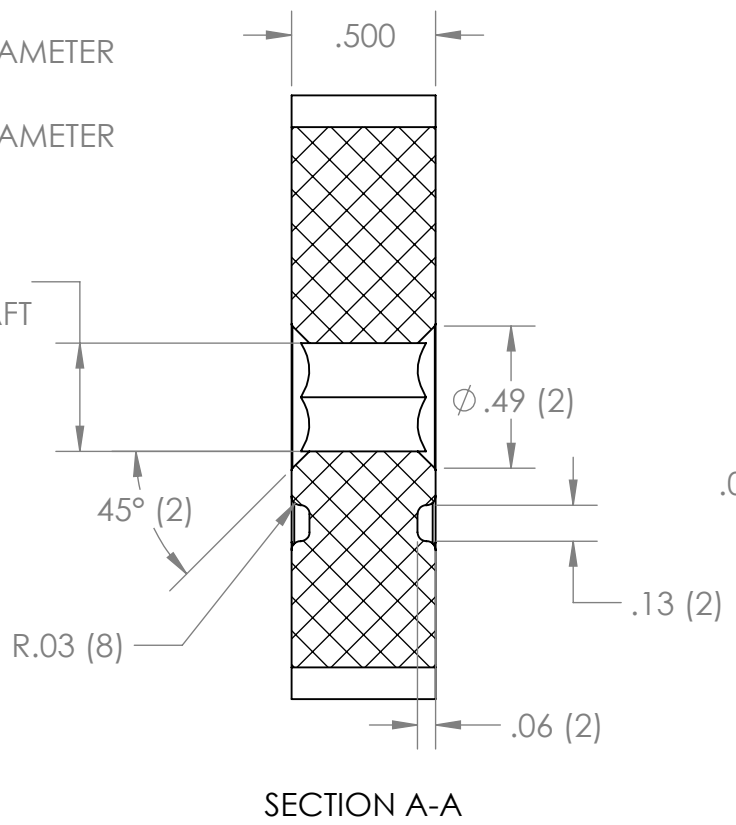
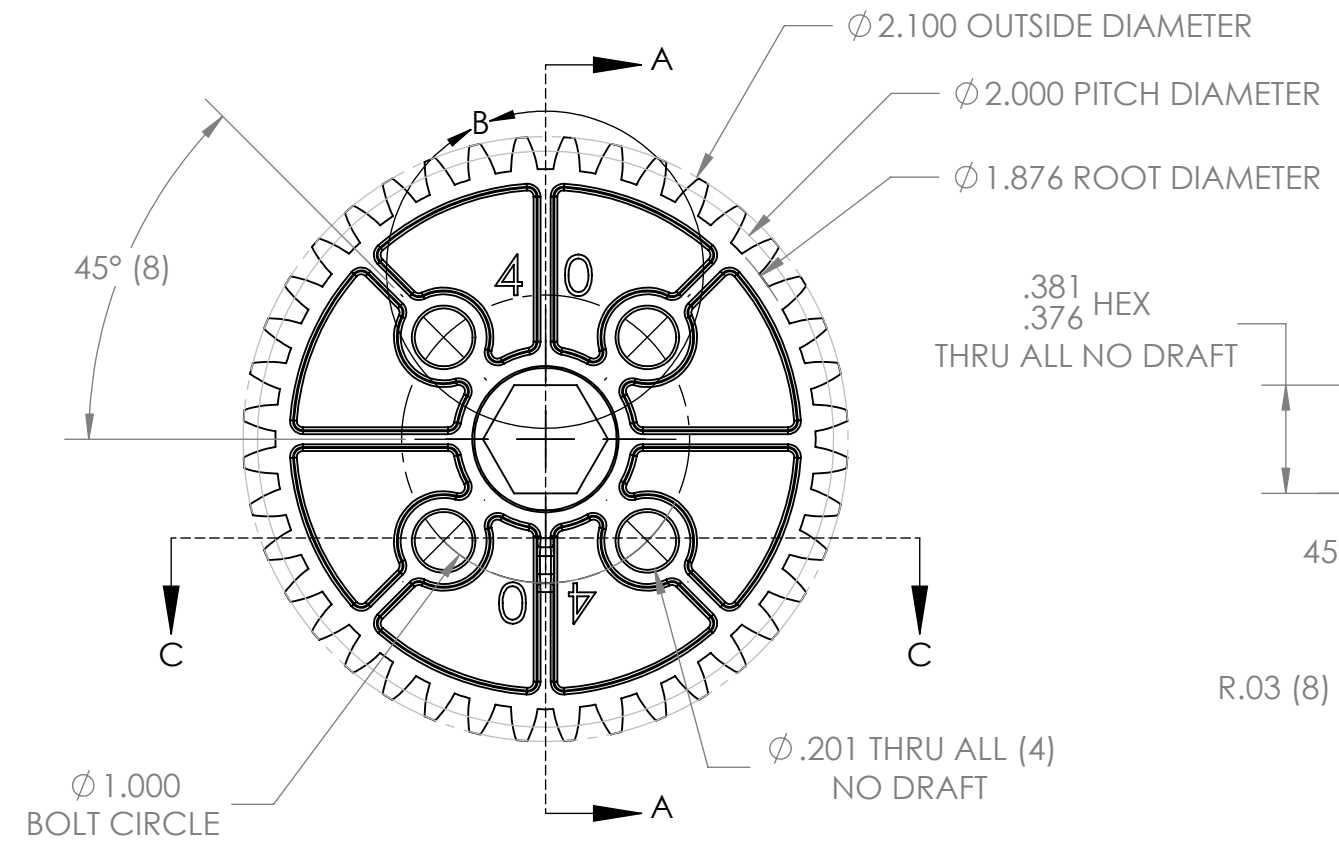

\*\*\* SEE CAD FOR ADDITIONAL TOOLPATH INFO\*\*\*

UNLESS OTHERWISE SPECIFIED:		COMMENTS:			
DIMENSIONS ARE IN INCHES		DUAL DIMENSIONS ARE IN MILLIMETERS.			
TOLERANCES:		BREAK ALL SHARP EDGES.		TITLE:	
FRACTIONAL	$\pm$ 1/16			40T 20DP 14.5PA	
ANGULAR: MACH	$\pm$ 1°			0.375IN HEX BORE GEAR	
ANGULAR: BEND	$\pm$ 5°			SIZE DWG. NO. REV	
ONE PLACE DECIMAL	$\pm$ 0.1			B am-5020_40 2	
TWO PLACE DECIMAL	$\pm$ 0.01			SCALE: 1.5:1 SHEET 1 OF 1	
THREE PLACE DECIMAL	$\pm$ 0.005				
FOUR PLACE DECIMAL	$\pm$ 0.0005				
MATERIAL	GRAY NYLON 33% GLASS FIBER	CHECKED	NAME NM	DATE 6/20/23	
FINISH	DEBURRED	ENG APPR.			
		MFG APPR.			
	DO NOT SCALE DRAWING	Q.A.			

4

3

2

1