

4

3

2

1

REVISION HISTORY			
REV.	DESCRIPTION	DATE	DRAWN BY
1	ORIGINAL PRINT	3/20/2023	P. YEUNG
2	MATERIAL CHANGE	6/20/2023	P. YEUNG

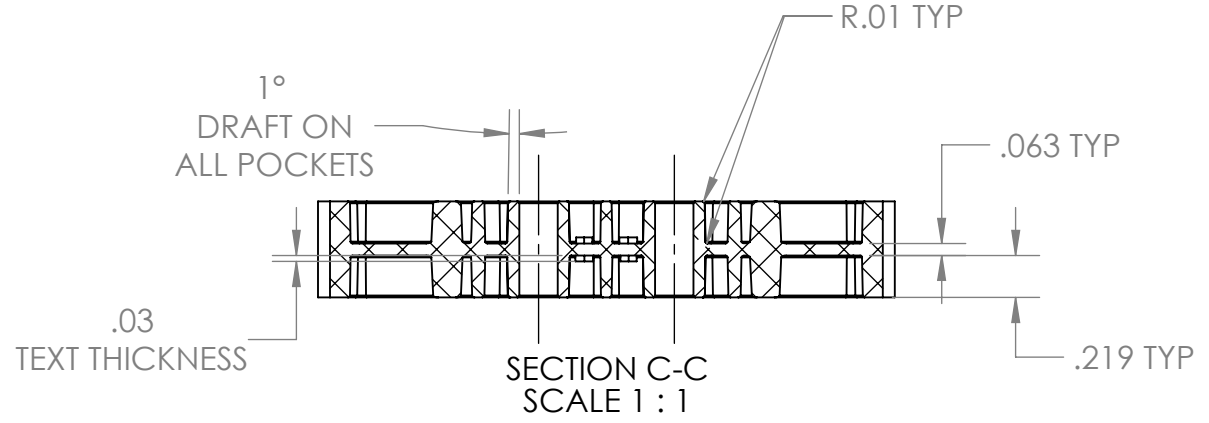
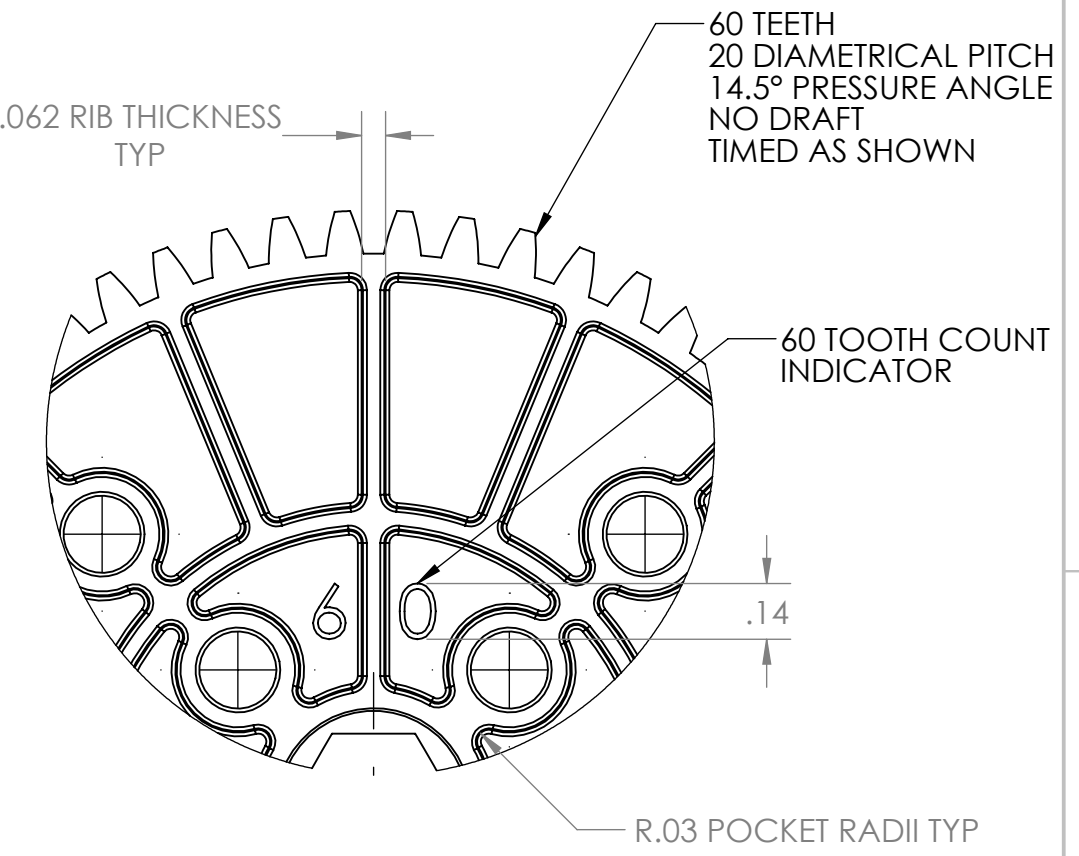
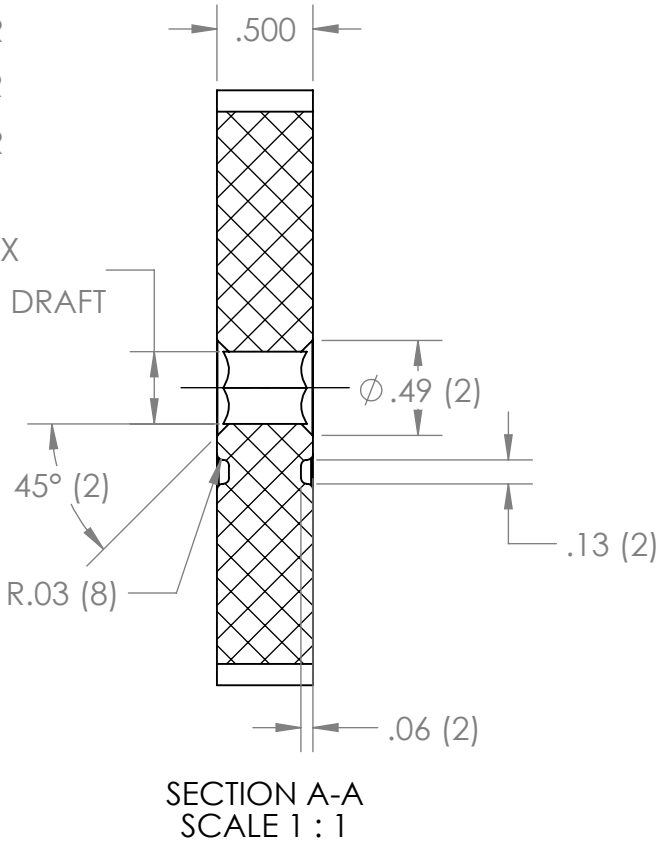
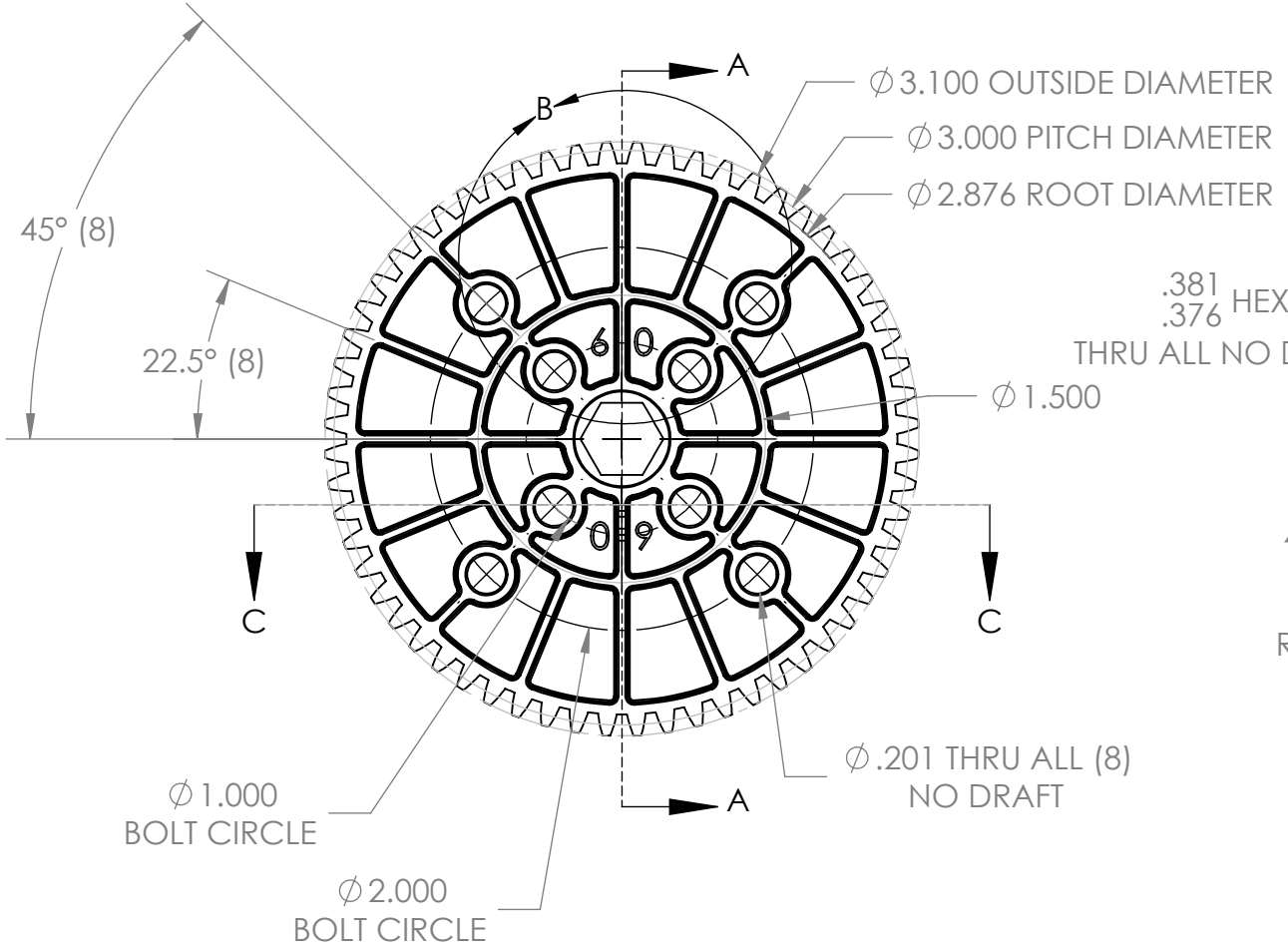

DETAIL B
SCALE 2 : 1

*** SEE CAD FOR ADDITIONAL TOOLPATH INFO***



UNLESS OTHERWISE SPECIFIED:		COMMENTS:				
DIMENSIONS ARE IN INCHES		DUAL DIMENSIONS ARE IN MILLIMETERS.				
TOLERANCES:		BREAK ALL SHARP EDGES.		TITLE:		
FRACTIONAL	$\pm 1/16$			60T 20DP 14.5PA		
ANGULAR: MACH	$\pm 1^\circ$			0.375IN HEX BORE GEAR		
ANGULAR: BEND	$\pm 5^\circ$			SIZE	DWG. NO.	REV
ONE PLACE DECIMAL	± 0.1			B	am-5020_60	2
TWO PLACE DECIMAL	± 0.01			SCALE: 1:2 SHEET 1 OF 1		
THREE PLACE DECIMAL	± 0.005					
FOUR PLACE DECIMAL	± 0.0005					
MATERIAL	GRAY NYLON 30% GLASS FIBER	CHECKED	NAME	DATE		
FINISH	DEBURRED	ENG APPR.	NM	6/20/23		
DO NOT SCALE DRAWING		MFG APPR.				
		Q.A.				

4

3

2

1