

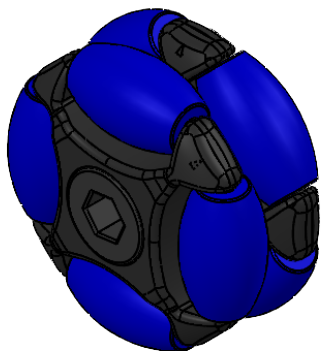

REVISION HISTORY			
REV.	DESCRIPTION	DATE	DRAWN BY
1	ORIGINAL PRINT	10/23/2023	P. YEUNG

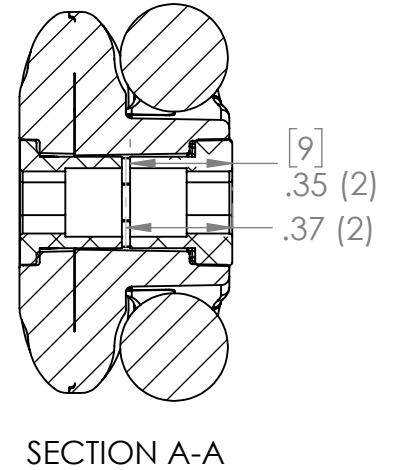
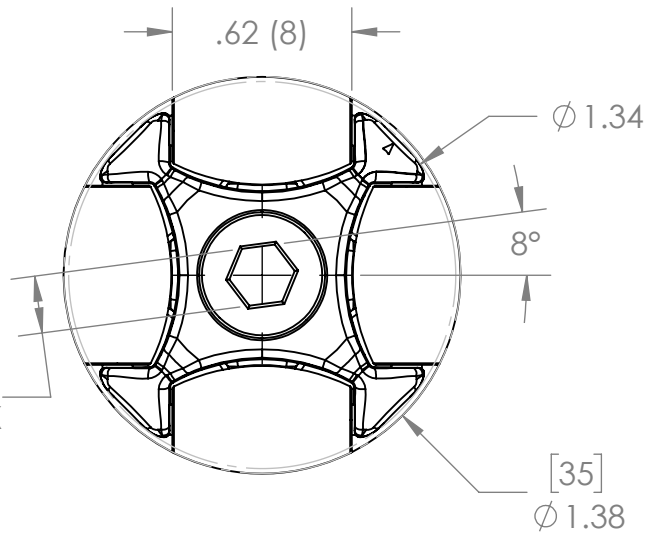
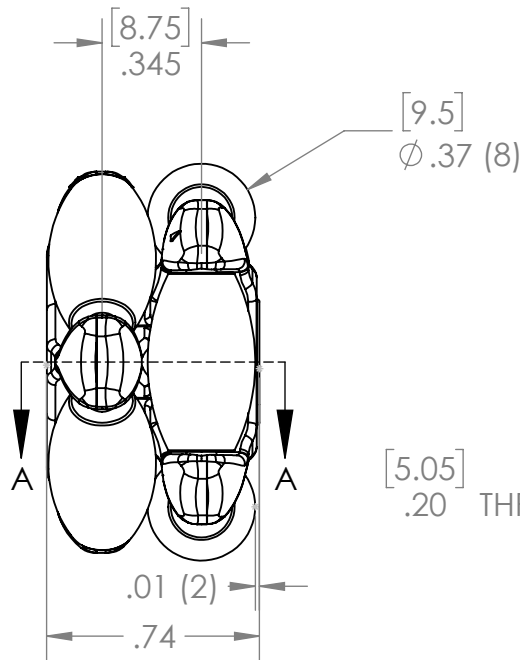

UNLESS OTHERWISE SPECIFIED:		COMMENTS:				
DIMENSIONS ARE IN INCHES		DUAL DIMENSIONS ARE IN MILLIMETERS.				
TOLERANCES:		BREAK ALL SHARP EDGES.		TITLE:		
FRACTIONAL	±1/16			35mm OMNI		
ANGULAR: MACH	±1°			5mm HEX BORE		
ANGULAR: BEND	±5°					
ONE PLACE DECIMAL	±0.1					
TWO PLACE DECIMAL	±0.01	MATERIAL		SIZE	DWG. NO.	REV
THREE PLACE DECIMAL	±0.005	ABS, TPE		A	am-5162	1
FOUR PLACE DECIMAL	±0.0005	FINISH				
DO NOT SCALE DRAWING		DEBURRED		SCALE: 1.5:1 SHEET 1 OF 1		
		CHECKED		NAME	DATE	
		ENG APPR.		NM	10/31/23	
		MFG APPR.				
		Q.A.				