

| REVISION HISTORY |                |          |          |
|------------------|----------------|----------|----------|
| REV.             | DESCRIPTION    | DATE     | DRAWN BY |
| 1                | ORIGINAL PRINT | 3/9/2023 | P. YEUNG |

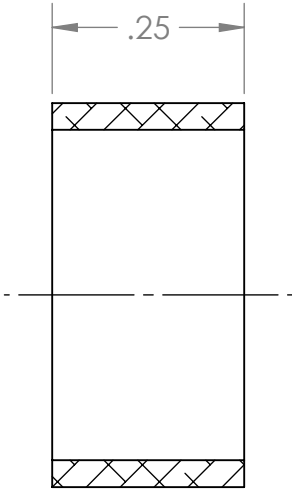

SECTION A-A

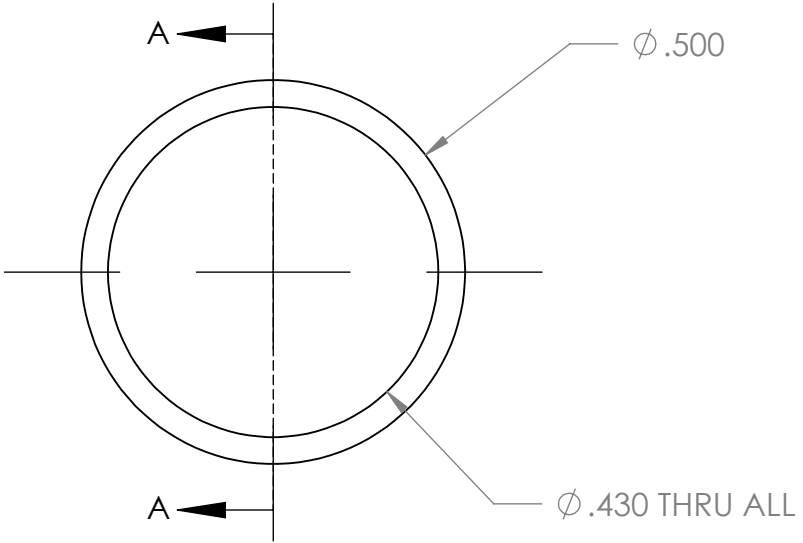

\*\*\* SEE CAD FOR ADDITIONAL TOOLPATH INFO\*\*\*

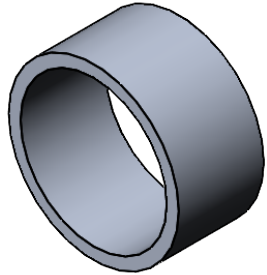

|                                 |            |                                     |      |   |              |     |
|---------------------------------|------------|-------------------------------------|------|---|--------------|-----|
| UNLESS OTHERWISE SPECIFIED:     |            | COMMENTS:                           |      |  |              |     |
| <b>DIMENSIONS ARE IN INCHES</b> |            | DUAL DIMENSIONS ARE IN MILLIMETERS. |      |   |              |     |
| TOLERANCES:                     |            | BREAK ALL SHARP EDGES.              |      | <b>TITLE:</b> 0.430 ID 0.500 OD<br>0.25 LONG<br>ALUMINUM SPACER                       |              |     |
| FRACTIONAL                      | ±1/16      |                                     |      |   |              |     |
| ANGULAR: MACH                   | ±1°        |                                     |      |   |              |     |
| ANGULAR: BEND                   | ±5°        |                                     |      |   |              |     |
| ONE PLACE DECIMAL               | ±0.1       |                                     |      |   |              |     |
| TWO PLACE DECIMAL               | ±0.01      |                                     |      | SIZE  | DWG. NO.     | REV |
| THREE PLACE DECIMAL             | ±0.005     |                                     |      | <b>A</b>  | am-1698      | 1   |
| FOUR PLACE DECIMAL              | ±0.0005    |                                     |      | SCALE: 4:1  |              |     |
| MATERIAL                        | AL 6061-T6 | CHECKED                             | NAME | DATE  | SHEET 1 OF 1 |     |
| FINISH                          | DEBURRED   | ENG APPR.                           | NM   | 3/9/23  |              |     |
| DO NOT SCALE DRAWING            |            | MFG APPR.                           |      |   |              |     |
|                                 |            | Q.A.                                |      |   |              |     |